



Miltenyi Biotec

CliniMACS Prodigy[®]

User Manual (U.S. Edition)

CAUTION:
Clinical Research System Limited by Federal (or United States) Law to Investigational
Use or under an FDA Approval.

CliniMACS[®] Prodigy

Copyright © 2023 Miltenyi Biotec and/or its affiliates. All rights reserved.

No part of this publication may be reproduced, stored in a retrieval system, transmitted, published, or distributed in any form or by any means, electronically, mechanically, by photocopying, microfilming, recording, or otherwise, without the prior written consent of Miltenyi Biotec; however, notwithstanding the foregoing, the owners of the CliniMACS Prodigy System may make copies solely for purposes of training personnel in the use and servicing of the unit within their business or organization.

CentriCult, CliniMACS, CliniMACS Prodigy, MACS, the Miltenyi Biotec logo, PepTivator, and TexMACS are registered trademarks or trademarks of Miltenyi Biotec B.V. & Co. KG and/or its affiliates in various countries worldwide. All other trademarks mentioned in this document are the property of their respective owners and are used for identification purposes only.

CliniMACS Prodigy®

User manual (U.S. Edition)

Material Titel 3: Process version 3.x

Issued: 2023-10

38401/04



Miltenyi Biotec B.V. & Co. KG

Friedrich-Ebert-Straße 68
51429 Bergisch Gladbach
Germany

Miltenyi Biotec Technical Support

☎ +49 2204 8306-3803

✉ technicalsupport@miltenyi.com

🏠 www.miltenyibiotec.com

Distributed by:

Miltenyi Biotec Inc.

2303 Lindbergh Street
Auburn, CA 95602
USA

Essential information

This user manual provides instructions, warnings, precautions, and other important information for the use of the CliniMACS Prodigy as well as warnings and precautions concerning the handling of biohazardous materials and cellular starting product. For details on processes run on the instrument, refer to the CliniMACS Prodigy user manual (U.S. Edition) for the respective application.

WARNING

The operation of the CliniMACS Prodigy System must be performed by trained operators only. Before putting the system into operation, carefully read and understand the safety information, warnings, precautions, and instructions for proper operation of the CliniMACS Prodigy provided in the instructions for use of the CliniMACS Prodigy System components (including, without limitation, the safety information in this user manual, chapter 3 “Important safety information”) and in any safety-related recommendations issued by Miltenyi Biotec. Pay special attention to all warnings displayed on the instrument or provided with consumables and accessories. The operator must adhere to all instructions and procedures at all times during the operation of the instrument, confirming that all safety information, warnings, precautions, and instructions are observed. Failure to follow the safety information, warnings, precautions, and instructions contained in the instructions for use could result in instrument malfunction, property damage, personal injury, and/or death. Equipment safety may be compromised if the instrument is not used according to the manufacturer’s instruction.

Retain the instructions for use for future reference. They should be kept accessible and readily available, together with all other safety and operating documentation, during the entire life cycle of the instrument for all personnel responsible for installation, operation, and maintenance.

Table of contents

1	Introduction	7
1.1	General information	7
1.2	Service information	8
1.2.1	CliniMACS Prodigy Information	8
1.2.2	Technical support	8
2	Glossary	9
2.1	Graphical depiction	9
2.2	Glossary of symbols	10
2.2.1	Safety symbols	10
2.2.2	Symbols used for labeling of products	11
2.2.3	Glossary of terms	14
3	Important safety information	25
3.1	Safety instructions for the CliniMACS Prodigy	28
3.1.1	Usage and installation	28
3.1.2	Electric hazards	29
3.1.3	Strong magnetic field	31
3.1.4	Optical radiation hazards	31
3.1.5	Chemical and biological hazards	32
3.1.6	Mechanical hazards	32
3.1.7	Gas hazards	33
3.1.8	Hot surfaces	33
3.1.9	Servicing and transport	33
3.2	Position of safety symbols	35

4	The CliniMACS Prodigy	37
4.1	Regulatory information	37
4.1.1	The CliniMACS Prodigy within the CliniMACS Prodigy Cell Separation System	38
4.1.2	The CliniMACS Prodigy within the CliniMACS Prodigy Cell & Gene Therapy Manufacturing System	40
4.2	Technical data	41
4.3	Components of the CliniMACS Prodigy	43
4.3.1	Housing and bag hangers	47
4.3.2	Monitor	48
4.3.3	Peristaltic pump	48
4.3.4	Magnet unit	49
4.3.5	CentriCult Unit	49
4.3.6	Gas mix unit	51
4.3.7	Sensors	52
4.3.8	Pinch valves	52
4.3.9	Connector panel	53
4.4	Accessories for the CliniMACS Prodigy	55
4.4.1	MACS TubeSealer	55
4.4.2	Bar code reader	55
4.4.3	CliniMACS Prodigy Supplementary Bag	56
4.4.4	CliniMACS Electroporator	56
4.4.5	CliniMACS Formulation Unit	57
4.5	Unpacking and installation	57
4.5.1	Scope of supply	57
4.5.2	Transport	58
4.5.3	Positioning	58
4.6	Cleaning and disinfection	59
4.7	Maintenance	60
4.8	Disposal	60

5	The CliniMACS Prodigy Software	61
5.1	Touchscreen	61
5.1.1	Use of touchscreen	61
5.1.2	General setup menu	62
5.2	Login, logout, and emergency stop	62
5.2.1	Login	63
5.2.2	Logout	63
5.2.3	Emergency Stop	64
5.3	The graphic user interface	64
5.3.1	Operating controls	64
5.3.2	Menus	70
5.4	Application Services	78
5.4.1	User Management	79
5.5	Alarm management	86
6	The CliniMACS Prodigy System	89
6.1	The CliniMACS Prodigy System components	89
6.2	Additional materials and equipment	90
6.3	Limitation	90
6.4	Warnings and precautions regarding the process	91
6.5	Warnings and precautions regarding the handling of biohazardous material	92
6.6	Warnings and precautions regarding the cellular starting product	93
7	Troubleshooting	95
7.1	Instrument malfunction or process failure	95
7.2	Instrument cleaning after leakage	95

8	Legal notes	97
8.1	Limited warranty	97
8.2	Trademarks	98
	Appendix	99

1

Introduction

1.1 General information

The CliniMACS Prodigy System offers a set of tools that enables high-quality and standardized cell processing for many different applications. The system is based on the magnetic cell separation technology (MACS® Technology) developed by Miltenyi Biotec.

The CliniMACS Prodigy represents the next generation in automated cell and liquid processing. With its integrated fluid transfer, centrifugation, and magnetic separation capability, the instrument enables fully automated cell processing and culture applications, as well as fluid handling. The instrument offers advanced integrated solutions to streamline cell-processing workflows. It provides a flexible platform enabling the separation of virtually any cell type, as well as customized separation protocols that meet specific process requirements. The different applications run on the instrument require the use of specific CliniMACS Prodigy System components as well as additional materials and equipment, as described in the CliniMACS Prodigy user manual (U.S. Edition) issued for the respective application (see also section 6.1 “The CliniMACS Prodigy System components”).

1.2 Service information

1.2.1 CliniMACS Prodigy Information

Record the model and serial number located on the back of the CliniMACS Prodigy below. Refer to these numbers whenever requesting information about the instrument or when requesting instrument service.

Catalogue no. (REF): _____

Serial no. (SN): _____

The software version is shown during the start-up phase of the instrument.

2

Glossary

2.1 Graphical depiction

The following chart depicts the panels used in this user manual to inform the user about potential risks if the outlined warnings and precautions are not followed. The hazard level classifies the hazard, as described below. The level, type, and source of the hazard, as well as potential consequences, prohibitions, and measures are indicated as follows. Icons on the left side specify the risk.

WARNING

Indicates a hazardous situation that, if not avoided, could result in death or serious injury.

CAUTION

Indicates a hazardous situation that, if not avoided, could result in minor or moderate injury.

NOTICE

Indicates information considered important, but not hazard-related (e.g., messages relating to property damage).

IMPORTANT

Advises the user of important practices or information not related to personal injury nor property damage.

2.2 Glossary of symbols

2.2.1 Safety symbols



General warning sign



Warning: Electricity



Warning: Magnetic field



Warning: Optical radiation



Warning: Biological hazard



Warning: High sound pressure level



Warning: Crushing of hands



Warning: Hot surface

2.2.2 Symbols used for labeling of products



Medical Device



European conformity approval with ID number 0123 (ID number of Notified Body: "TÜV SÜD Product Service GmbH, Munich").



Eurasian Conformity mark



NRTL certification mark: Product meets consensus-based standards of safety, required by the Occupational Safety/Health Administration (OSHA), determined by the Nationally Recognized Testing Laboratories (NRTL) TÜV SÜD



Consult instructions for use



Caution



Manufacturer



Date of manufacture



Protective conductor terminal (ground)



Separate collection for waste of electrical and electronic equipment



Fuse



Keep dry



Fragile, handle with care



This way up



"OFF" (power)



"ON" (power)



Installation date



Do not re-use



Do not use if package is damaged



The packaging is PVC free



Use-by date



Temperature limit



Non-pyrogenic fluid path















Batch code



Part number



Contents of the packaging

	Catalogue number
	Serial number
	Unique Device Identification
	Sterilized using aseptic processing techniques
	Sterilized using steam or dry heat
	Sterilized using irradiation
	Non-sterile
	Single sterile barrier system
	Single sterile barrier system with protective packaging outside
	Phone
	Fax
	E-Mail
	Website

2.2.3 Glossary of terms

Alarm connector	Relay circuit connector for the connection of the instrument to an external alarm system
Antigen Bag	Bag containing antigen, part of the CliniMACS Prodigy TS 500
Apheresis	A method of collecting blood in which the whole blood is withdrawn, a desired component selected and retained, and the remainder of the blood returned to the donor
Application Bag	Bag for cellular starting product, part of CliniMACS Prodigy Tubing Sets
AUX 3 pin connector (for CliniMACS Prodigy manufactured until July 2020)	Connector for compatible external devices, currently non-functional
AUX 5 pin connector	See TubeSealer port
Bag compartment	Compartment of the CliniMACS Prodigy for the storage of bags during instrument operation
Bag hanger	Component of the CliniMACS Prodigy on which elements of the CliniMACS Prodigy Tubing Sets, such as buffer bags, application bags, or vials are mounted
Bar code	Machine-readable representation of data, e.g., part number, batch code, or use-by date, indicated on required materials
Bar code reader	The bar code reader serves as a data input device to scan bar codes printed on, e.g., CliniMACS Materials, needed for process execution with the CliniMACS Prodigy System.
Bone marrow aspirate	Sample of bone marrow taken by insertion of a needle through the bone drawn into a syringe
CAN	Controller Area Network
CAN connector	Connector used for service purposes only

Cellular starting product	Cell-containing product used as starting material for the CliniMACS Prodigy Applications, e.g., leukapheresis harvest, PBMCs, or bone marrow
CentriCult™ Unit	The CentriCult Unit, as a part of the CliniMACS Prodigy, comprises a cell processing compartment featuring the following components: Layer Detection Camera, microscope camera, heat exchange unit, chamber lock adapter, and the lid of the unit. This compartment can be temperature and atmosphere controlled for centrifugation, incubation, and cell cultivation.
CentriCult Unit lid	Protection cover locking the CentriCult Unit
Centrifugation sensor	Part of the CentriCult Unit to control the centrifugation speed
Chamber	Compartment for fractionation, washing, and labeling by centrifugation and for cultivation of cells, part of the CliniMACS Prodigy Tubing Sets
Chamber drive unit	Unit which drives the chamber within the CentriCult Unit
Chamber lock adapter	The chamber lock adapter holds the chamber of the tubing set and connects it to the chamber drive unit
Channel clip	Blue clip holding the tubing outside the CentriCult Unit in position
Check valve	Check valves are two-port valves, meaning they have two openings in the body, one for fluid to enter and the other for fluid to leave. An important concept in check valves is the cracking pressure which is the minimum upstream pressure at which the valve will operate.
Cleaning solution	Aqua bidest for injection use. The cleaning solution is used for cleaning the inner tubing and chamber of the tubing set during specific cleaning process steps. The cleaning solution is not part of the CliniMACS Prodigy System.

Cleaning solution bag	Bag containing the cleaning solution. The cleaning solution bag is not part of the CliniMACS Prodigy Tubing Sets.
CliniMACS PBS/EDTA Buffer (3000 mL)	Buffer used for cell preparation and cell separation with the CliniMACS System: PBS (phosphate-buffered saline), supplemented with 1 mM EDTA, pH 7.2. Before use, CliniMACS PBS/EDTA Buffer (3000 mL) must be supplemented with pharmaceutical-grade HSA to a final concentration of 0.5% (weight/volume, i.e. 5 g HSA per liter buffer). HSA-supplemented buffer is called process buffer.
CliniMACS Electroporator	The CliniMACS Electroporator is a fully automatic instrument for the electroporation of eukaryotic cells in combination with the CliniMACS Prodigy. After electroporation, cells are further processed by the CliniMACS Prodigy.
CliniMACS Electroporator Buffer	Buffer used for the electroporation of cells with the CliniMACS Electroporator
CliniMACS Formulation Unit	The CliniMACS Formulation Unit is an instrument accessory for the automated final formulation and sampling of eukaryotic cells in combination with the CliniMACS Prodigy. The CliniMACS Formulation Unit enables the user to take cell samples during or after processing by the CliniMACS Prodigy.
CliniMACS Prodigy	The CliniMACS Prodigy is an instrument for automated cell processing. This instrument offers integrated solutions for cell processing workflows: from cell separation through cell culture to formulation of the final product.
CliniMACS Prodigy Supplementary Bag	The CliniMACS Prodigy Supplementary Bag is intended to help reduce the user's contact to accidentally emitted, potentially infectious sample material out of the CliniMACS Prodigy Tubing Set.

CliniMACS Prodigy Tubing Set	Set of tubing, connectors, columns (as applicable to the tubing set), centrifugation chamber, pump tubing, and bags through which the cell suspension is processed. The different tubing sets are designed for the specific needs of the respective application.
EDTA	Ethylene-diamine-tetra-acetic acid
Electroporation cuvette	The electroporation cuvette is part of the CliniMACS Prodigy EP-4 and CliniMACS Prodigy EP-2 and placed in the holder of the Electroporation Unit. Cells and nucleic acids, proteins, or other small molecules are filled into the electroporation cuvette and a strong electrical impulse is applied on the cells.
Electroporation unit	The Electroporation Unit includes a holder for the electroporation cuvette and applies an electrical impulse onto the cuvette.
Elution buffer	Solution for eluting cells into the Target Cell Bag and Non-Target Cell Bag
Elution buffer bag	Bag containing the elution buffer, part of the CliniMACS Prodigy Tubing Sets
Filtration Bag	Bag for filtration of cellular product which is labeled with depletion reagent before magnetic cell separation, part of specific CliniMACS Prodigy Tubing Sets.
×g	Multiples of the Earth's gravitational acceleration
Gas inlet connector	Three gas inlet connectors at the rear side of the instrument for the connection of external gas supplies
Gas mix unit	The gas mix unit inside the CliniMACS Prodigy is used to prepare a mixture of up to three different gases for cell culture purpose. Only CO ₂ , compressed air, and optionally N ₂ may be used with the CliniMACS Prodigy.

Gas outlet connector	Single outlet connector at the front of the instrument for connection of the gas mix unit to the tubing set to allow setting of the atmosphere within the cultivation chamber
Grounding screw	Part of the connector panel at the rear side of the CliniMACS Electroporator
Guide pin	Part of the peristaltic pump to hold the pump tubing in place
Heat Exchange Cartridge (HEC)	Part of specific CliniMACS Prodigy Tubing Sets which allows temperature control of fluids within the tubing set
Heat exchange unit	Part of the CentriCult Unit ensuring constant temperatures within the unit
Hematopoietic progenitor cells	Progenitor cells of lymphoid, myeloid, and erythroid lineage
Housing	Cabinet of the CliniMACS Prodigy including bag hangers and a bag tray. A touchscreen is connected to the housing.
HSA	Human serum albumin. Pharmaceutical-grade HSA, approved in your country, is necessary as a buffer supplement when used with the CliniMACS Prodigy System and is not supplied as part of the CliniMACS System.
Infusion solution	Buffer or media in which cells are finally formulated after cell processing. The composition of this solution is dependent on further down-stream use of the cell product and can be chosen individually by the operator. The infusion solution is not part of the CliniMACS Prodigy System.
Infusion solution bag	Bag containing the infusion solution. The infusion solution bag is not part of the CliniMACS Prodigy Tubing Sets.

Inlet tube	Closed tubing, which allows sterile welding of additional bags, accessories etc., part of specific CliniMACS Prodigy Tubing Sets.
Intermediate Storage Bag	Bag for intermediate storage of labeled cells, part of specific CliniMACS Prodigy Tubing Sets
Labeling	Binding of cells by magnetic labeling reagent, e.g., CliniMACS CD34 Reagent to CD34 positive cells
Layer Detection Camera	Camera system using proprietary technology for the detection of the different interlayers during centrifugation, allowing controlled aspiration of cells or fluids, part of the CentriCult Unit
Leukapheresis	Apheresis collecting leukocytes
Liquid sensor	The CliniMACS Prodigy is equipped with four liquid sensors that monitor the flow of liquid in the tubing set based on an ultrasonic principle. It allows detection of air bubbles.
Luer connector	Screw coupling, part of the CliniMACS Prodigy Tubing Sets
MACS TubeSealer	Heat sealer used for sealing PVC and EVA tubes of the CliniMACS Prodigy Tubing Sets installed on the CliniMACS Prodigy
Magnet unit	The magnet unit is used to separate magnetically labeled cells from non-labeled cells. It includes a movable, strong permanent magnet and a column holder for the separation column in which the magnetically labeled cells are retained.
Magnetic antibody	A super-paramagnetically labeled antibody
Medium bag	Bag containing medium (e.g., TexMACS™ Medium). The medium bag is not part of the CliniMACS Prodigy Tubing Sets.
Microscope camera	Optical unit for microscopic examination of cells cultured within the chamber, part of the CentriCult Unit

Monoclonal antibody	A single type of antibody that is directed against a specific epitope (antigen, antigenic determinant) and is produced by a single clone of B cells or a single hybridoma cell line, which is formed by the fusion of a lymphocyte cell with a myeloma cell.
Non-Target Cell Bag	Bag containing the non-target cell fraction, part of specific CliniMACS Prodigy Tubing Sets
Non-Target Cell Bag Depletion	Bag containing labeled cells (non-target cell fraction) after depletion procedure, part of specific CliniMACS Prodigy Tubing Sets
PepTivator®	PepTivators are pools of lyophilized peptides. PepTivator peptide pools consist of mainly 15mer peptides with eleven amino acids overlap, covering the whole sequence of the protein antigen.
Peristaltic pump	Instrument part used to control the flow rate of fluid within the tubing set
Pinch valve	Part of the CliniMACS Prodigy: 24 magnetic valves are used to fix the CliniMACS Prodigy Tubing Set onto the instrument and to ensure controlled flow pathways within the tubing set throughout the procedure
Plasma transfer set	Connector set with two couplers to connect two bags. A plasma transfer set may be required for some processes. The plasma transfer set is not part of the CliniMACS Prodigy Tubing Sets.
Power-CAN connector	Connector for external devices with higher power requirements (such as the CliniMACS Electroporator)
Pre-column	Column which serves as a filter to trap cells that interact non-specifically with the column matrix, part of specific CliniMACS Prodigy Tubing Sets
Pre-column holder	Holder connected to bag hanger to hold the pre-column of the tubing set in place, part of the CliniMACS Prodigy

Pressure sensor	Integral part of the peristaltic pump that monitors the pressure within the tubing set to allow for detection of leakages or clogging of the tubing set
Priming	Step prior to cell separation in which buffer or medium is flushed through the tubing set
Priming Bag	Bag containing buffer from priming step, part of specific CliniMACS Prodigy Tubing Sets
Process	Software program designed for cell processing and culture applications. The operator is able to choose from a menu of processes depending on the intended procedure.
Process buffer	CliniMACS PBS/EDTA Buffer (3000 mL) supplemented with HSA to a final concentration of 0.5% (w/v)
Process buffer bag	Bag containing CliniMACS PBS/EDTA Buffer (3000 mL) supplemented with HSA to a final concentration of 0.5% (w/v)
Process medium	Medium for cultivation and processing of cells within the tubing set
Pump safety switch	Sensor that prevents pump operation when the pump door is open, part of the CliniMACS Prodigy
QC Bag	Bag containing automatically collected in-process QC-samples, part of specific CliniMACS Prodigy Tubing Sets
RBC	Red blood cells
Reapplication Bag	Bag for enriched cells prior to cultivation, part of the CliniMACS Prodigy Tubing Sets
Reservoir Bag	Bag containing the elution buffer, part of specific CliniMACS Prodigy Tubing Sets
Retaining ring	Plastic ring at each end of the pump tubing that enables the pump tubing to remain in its proper location, part of the CliniMACS Prodigy Tubing Sets

rpm	Revolutions per minute
Safety valve	Safety valve of the gas mix unit, positioned at the rear side of the instrument
Separation column	Column in which magnetically labeled cells are retained when exposed to the magnetic field, part of the CliniMACS Prodigy Tubing Sets
Separation column holder	Molded guides in the magnet unit that holds the separation column in place
Separation reagent	Reagent for magnetic labeling of cells, e.g., CliniMACS CD34 Reagent
Signal lamp	LED signal lamp positioned at the top of bag hanger A to provide optical signals about the status of the instrument in operation
Supplementary Bag compartment	Instrument part underneath the CentriCult Unit for the storage of the CliniMACS Prodigy Supplementary Bag
Target Cell Bag	Bag containing the target cell fraction, part of specific CliniMACS Prodigy Tubing Sets
Test Cuvette Adapter	The Test Cuvette Adapter (TCA) serves for testing electroporation parameters in a small scale with electroporation cuvettes used in manual electroporation devices.
Touchscreen	TFT LCD type with touchscreen functionality as part of the CliniMACS Prodigy to guide the operator through the setup procedure and allow monitoring of automatic instrument operations. Located in the touchscreen are the central control board and the data storage unit.
Transfer bag	Bag with a tubing and a spike at the end. The transfer bag is not part of the CliniMACS Prodigy Tubing Sets.
TubeSealer port	Connector for the MACS TubeSealer

Tubing duct	Instrument part between the housing and the lid of the CentriCult Unit serving as save passageways for the tubing of the tubing set from inside the CentriCult Unit to the outside of the unit
USB	Universal serial bus
USB ports	Standard USB ports to allow easy data transfer
User program	Software program defining a specific sequence of cell processing steps, e.g., centrifugation, liquid transfer, or controlled incubation.
Vial adapter	Adapter on the CliniMACS Prodigy Tubing Sets to connect the vial (e.g., CliniMACS Reagent vial)
Vial holder	Part of the bag hanger assembly to hold a vial in place
Waste Bag	Bag containing discarded liquids during operation of the CliniMACS Prodigy, part of specific CliniMACS Prodigy Tubing Sets
WBC	White blood cells

3

Important safety information

WARNING

The operation of the CliniMACS Prodigy System must be performed by trained operators only. Before putting the system into operation, carefully read and understand the safety information, warnings, precautions, and instructions for proper operation of the CliniMACS Prodigy provided in the instructions for use of the CliniMACS Prodigy System components (including, without limitation, the safety information described in this chapter) and in any safety-related recommendations issued by Miltenyi Biotec. Pay special attention to all warnings displayed on the instrument or provided with consumables and accessories. The operator must adhere to all instructions and procedures at all times during the operation of the instrument, confirming that all safety information, warnings, precautions, and instructions are observed. Failure to follow the safety information, warnings, precautions, and instructions contained in the instructions for use could result in instrument malfunction, property damage, personal injury, and/or death. Equipment safety may be compromised if the instrument is not used according to the manufacturer's instruction.

Retain the instructions for use for future reference. They should be kept accessible and readily available, together with all other safety and operating documentation, during the entire life cycle of the instrument for all personnel responsible for installation, operation, and maintenance.

 **WARNING**

Hazards to users, instrument damage, and/or malfunction, unpredictable results, premature wear and tear, and/or reduced life time of the instrument if the following safety information, warnings, precautions, and instructions are not observed at all times when using the instrument.

- Always operate, handle, use, and maintain the instrument in accordance with the safety information, warnings, precautions, instructions, and recommended procedures provided in the user manuals and other written instructions issued by Miltenyi Biotec. Do not deviate from these operating instructions and procedures.
- Always ensure that the instrument is operated, handled, used, and maintained only by appropriately skilled and trained personnel familiar with the construction, operation, and hazards involved with the instrument. The instrument is intended for use in the professional facility healthcare environment. The instrument is not intended to be used near active HF surgical equipment. The customer or user should assure that it is used in such an environment.
- Always operate, handle, use, and maintain the instrument in compliance with all applicable laws, rules, regulations and administrative provisions, including, without limitation, all regulations regarding health and safety at work and, as appropriate, the safety of medical devices, as applicable, at the location where the instrument is operated.
- Always use the instrument for its designated purpose (in accordance with the product documentation and within its performance limits), and not in any other manner or for any other purpose.
- Safety and performance of the instrument may be compromised. Never use the instrument with consumables, accessories, transducers, and/or cables other than those approved by Miltenyi Biotec to ensure safe and proper operation of the instrument.
- **Note:** The use of consumables, accessories, transducers, and/or cables not expressly approved by Miltenyi Biotec could void the warranty and/or invalidate the authority to operate this instrument under applicable regulations.

- Always follow the maintenance recommendations of Miltenyi Biotec and appropriate product standards. **Note:** Installation, maintenance, and service of the instrument must only be performed by authorized local Miltenyi Biotec Service Provider. Ensure that the instrument is not put into operation unless and until all initial and periodic maintenance and instrument safety checks have been successfully performed.
- Defects should be addressed immediately. If there is any doubt regarding the proper functioning of the instrument, **do not** use the instrument and contact the authorized local Miltenyi Biotec Service Provider or Miltenyi Biotec Technical Support as soon as possible.
- Never change or modify the instrument except with Miltenyi Biotec's prior written approval. **Note:** Changes or modifications to the instrument not expressly approved by Miltenyi Biotec could void the warranty and/or invalidate the operator's authority to operate the instrument under applicable regulations.

 WARNING

Risk of death, serious personal injury, and/or property damage, instrument malfunction, or damage, premature wear and tear, and reduced instrument life time. Failure to comply with the safety information, warnings, precautions, and instructions in the user manuals (and in other safety related publications issued by Miltenyi Biotec for use with the instrument) could lead to improper or incorrect use, handling or care of the product and cause a hazard, and could result in death, serious personal injury, and/or property damage, instrument malfunction, or damage, premature wear and tear, and reduced instrument life time, and may void the warranty and/or invalidate the authority to operate the instrument under applicable regulations. Always follow the safety information, warnings, precautions, and instructions in the user manuals (and in other safety related publications issued by Miltenyi Biotec for use with the instrument). Miltenyi Biotec accepts no liability for consequences arising from failure to comply with the safety information, warnings, precautions, and instructions provided herein.

If concerned about the safe use of the instrument or if additional safety information regarding the CliniMACS Prodigy System is required, contact the authorized local Miltenyi Biotec Service Provider or Miltenyi Biotec Technical Support.

3.1 Safety instructions for the CliniMACS Prodigy



In the event of an unexpected process abortion or messages on the screen that advise the operator to contact technical support, immediately contact the Miltenyi Biotec Technical Support. If secure operation is no longer possible, immediately switch off and unplug the instrument from the power outlet, and contact Miltenyi Biotec Technical Support or an authorized local Miltenyi Biotec Service Provider.

3.1.1 Usage and installation

CAUTION

Risk of process failure. If alarm signals are not recognized and the required actions are not executed or confirmed there is the risk of process failure. Confirm that optical and acoustical alarm signals can be recognized by the operator at any time during the process.

WARNING

Risk of improper operation due to increased electromagnetic emission or decreased electromagnetic immunity. The use of consumables, accessories, and cables other than those specified or provided by the manufacturer of this equipment could result in increased electromagnetic emission or decreased electromagnetic immunity of this equipment and result in improper operation. Medical electrical equipment requires special precautions regarding electromagnetic compatibility (EMC) and must be installed and placed in service according to the EMC information (see Appendix). Portable and mobile RF communications equipment can affect medical electrical equipment. Only use the instrument with accessories, transducers, and/or cables approved by Miltenyi Biotec. Installation of the CliniMACS Prodigy must only be performed by an authorized local Miltenyi Biotec Service Provider.

The CliniMACS Prodigy may be used repeatedly. It is not intended for disposal after single use. Contact the local authority governing electrical power supply, building construction, maintenance, or safety for more information regarding the installation of the equipment.

CAUTION

Suitability of the target cells for clinical application may be compromised. The target cells must be analyzed, otherwise the suitability for clinical application may be compromised. Examine the target cells regarding quality and quantity in view of their intended use.

3.1.2 Electric hazards



Electrical instruments pose the risk of an electric shock, electric short circuit, and overheating. Electric shock may lead to severe personal injury or death. Do not use the instrument in case of visible damage or if it has been dropped. Contact Miltenyi Technical Support.

An electrical short and overheating may lead to the spread of fire.

The CliniMACS Prodigy is a Protection Class I device and may only be plugged into an outlet with a grounded connection.

Electronic equipment may emit sparks that could ignite combustible vapors or dusts leading to explosion or spread of fire.

⚠ WARNING

Risk of electric shock, electrical short, and spread of fire. The housing of the instrument reduces the risks of electric shock, electrical short, and spread of fire. Opening any cover of the instrument interrupts this protective measure. Do not remove or penetrate any cover of the instrument. Only an authorized local Miltenyi Biotec Service Provider may open the instrument or exchange spare parts.

Risk of electric shock or damage to the instrument. Risk of electric shock or damage to the instrument if the instrument is cleaned with excessive amount of cleaning or while switched on. Only clean the instrument when it is switched off and the power cord is unplugged. Avoid ingress of any liquid into the valves and into the liquid sensor. Do not use an excessive amount of cleaning or disinfection agents to avoid spilling into the gas outlet connector. After cleaning, dry all excess liquid from the valves, pump head, gas outlet connector etc.

If flames or smoke appear, immediately switch off the instrument, unplug it from the electrical outlet, and contact an authorized local Miltenyi Biotec Service Provider or Miltenyi Biotec Technical Support.

The instrument is intended for indoor use only. Water ingress may lead to an electrical short and the risk of electric shock or spread of fire. Do not use the instrument in a wet or damp location or if it has been exposed to moisture. Avoid high humidity or condensation and protect the instrument from contact with water. Special care must be taken while handling fluids. Clean spillages immediately. Do not allow fluids to enter the interior of the instrument. Avoid ingress of any liquid into the valves. Do not operate the instrument if liquids have spilled into the instrument. Fluid containers

must be handled with caution when in the area of the instrument. After moving the instrument from a cold environment, such as a cold room at +4 °C (+39 °F), to room temperature, condensing liquid droplets may form inside the instrument. It is necessary to wait for the instrument to dehumidify before operating the instrument. Unplug the instrument from the power outlet before cleaning. Do not use liquid or aerosol cleaning agents; always use a damp cloth.

Risk of overheating. Risk of overheating in case of reduced air circulation. Do not place the instrument with the back side directly against the wall. Keep at least 14 cm distance to allow free air circulation. Allow sufficient space around the ventilation slots at the rear and underneath the instrument. Take into consideration that the instrument requires adequate air circulation for heat exchange and cooling. Read the chapter “Important safety information” to avoid the risk of overheating.

Ambient air temperature may not be adequate to cool the instrument to acceptable operating temperatures without adequate circulation. Confirm the room in which the instrument is operated has adequate air circulation. The instrument should not be placed next to radiators, heat registers, stoves, or other pieces of equipment (including amplifiers) that produce heat. Prevent direct exposure of the instrument to sunlight. Slots and openings of the instrument are provided for ventilation and should never be blocked or covered, as these protect the instrument from overheating. Do not place the instrument within a built-in apparatus or a confined space, such as a shelf rack, unless the apparatus has been specifically designed to accommodate the instrument, proper ventilation is provided, and the mounting instructions for the instrument have been followed.

Assure that the main switch, as well as the outlet for the power cord are easily accessible and located as close to the operator of the instrument as possible. If it is necessary to disconnect the power supply, unplug the cord from the power outlet.

The instrument is equipped with a three-wire electrical grounding-type plug that has a third pin for grounding. This plug only fits into a grounded power outlet. This is a safety feature. Do not try to insert the plug into a non-grounded power outlet. If the plug cannot be inserted into the outlet, contact the local electrician to replace the outlet.

The instrument should only be operated from a power source indicated on the product’s electrical ratings label. For questions about the type of power source to use, contact the authorized local Miltenyi Biotec Service Provider. Do not use extension cords or power strips. Do not overload an electrical outlet.

⚠ CAUTION

Risk of termination of the separation process. Based on technical limitations of the internal power supply voltage of the instrument, interruptions on power supply input lines for longer than 10 ms may lead to termination of the separation process (power failure). The separation process cannot be resumed after a power failure. It is recommended that the instrument is powered from an uninterruptible power supply or a battery that starts within 10 ms.

3.1.3 Strong magnetic field

⚠ WARNING

Risk of severe personal injury for persons carrying pacemakers, brain shunts, or electronic medical implants. The CliniMACS Prodigy is equipped with an extremely strong permanent magnet generating a strong magnetic field. There is a risk of severe personal injury for persons carrying pacemakers, brain shunts, or electronic medical implants. Always maintain a distance of at least 30 cm from the magnet cover. Keep any magnetic information carriers (such as credit cards or magnetic tapes), electronic equipment (such as hearing aids, measuring and control instruments, computers, and watches), and magnetizable tools and objects at a distance of at least 30 cm from the magnet cover. These items may be affected or damaged by the magnetic field.

3.1.4 Optical radiation hazards

The CliniMACS Prodigy is equipped with a light emitting diode (LED) for the signal lamp at the left bag hanger (position A).

⚠ CAUTION

The optical radiation emitted from the LED may be harmful to the eyes at close viewing distances. Light emission is especially powerful when bag hanger A is disassembled. Do not disassemble the bag hanger A while the instrument is switched on.

3.1.5 Chemical and biological hazards

WARNING



Risk of severe personal injury or death. Depending on the biological material used, contamination or infection may lead to severe personal injury or death. Always wear personal safety equipment in accordance with warnings and precautions, in particular if biohazardous material is or has been used.

Wear protective gloves, protective clothing, and safety goggles to prevent contact with skin and eyes. Defective or inadequate safety equipment might endanger the operator. If hazardous material has been used or spilled, take care to thoroughly decontaminate the instrument.

After running the sample and prior to decontamination, the CliniMACS Prodigy should be treated as a biohazard (see section 4.6 "Cleaning and disinfection"). Waste disposal must be in accordance with local regulations.

3.1.6 Mechanical hazards

CAUTION



Risk of internal damage. Movement or vibration may affect the instrument. Do not place the instrument next to equipment that vibrates or can cause the instrument to move. Imbalance during centrifugation can lead to substantial vibrations. Shut down the instrument when substantially strong vibrations occur. Contact Miltenyi Biotec Technical Support for assistance.

Keep away from all moving parts. Do not lean on the CliniMACS Prodigy or the CentriCult Unit.

3.1.7 Gas hazards

WARNING

Gas hazard. Escaping CO₂ and N₂ can be a potential hazard to the user, especially during long-lasting incubation procedures. An automated gas alarm system and monitoring of the gas concentration in the room is required. An appropriate ventilation of the room must be ensured. Connection to the gas supply must be performed according to national and local requirements. Maximum gas concentration in the room may not be exceeded. A CO₂ concentration of more than 4.00 ppm (9,100 mg/m³) and an O₂ concentration of less than 17 vol.-% of the air is presently regarded by some authorities as the threshold at which a hazard may be caused. The safety of the gas supply system is the responsibility of the user.

3.1.8 Hot surfaces

CAUTION



Risk of burns. The surface of the heat exchange unit and the heat exchange cartridge (HEC) may become hot enough to cause burns if touched. A high temperature may also occur at the heat sink on the back of the instrument. Do not touch the heat exchange unit, the HEC, the heat sink on the back of the instrument while the instrument is in operation.

3.1.9 Servicing and transport

WARNING

Hazards to users, unpredictable results, instrument malfunction or damage, premature wear and reduced life time of the instrument. Improper or incorrect servicing or repair of the instrument can cause hazards to users, lead to unpredictable results, instrument malfunction or damage, premature wear and reduced life time of the instrument, and may void the warranty. Unless otherwise specifically noted in this user manual, do not service the CliniMACS Prodigy. Service and repair may only be performed by authorized local Miltenyi Biotec Service Provider.

Using unauthorized replacement or spare parts can cause malfunction of the instrument and impair results. Miltenyi Biotec does not honor any warranty or accept any responsibility for instrument failure or damages resulting from the use of inappropriate replacement or spare parts. After completing any services or repairs, authorized local Miltenyi Biotec Service Providers perform all required safety checks to ensure that the instrument is fully functional.

For information about Miltenyi Biotec's instrument service and support arrangements, contact the authorized local Miltenyi Biotec Service Provider or Miltenyi Biotec Technical Support.

 **CAUTION**

Risk of internal damage. Internal damage can occur if the instrument is subjected to excessive vibration or is dropped. The instrument should be transported with care in packaging specified by Miltenyi Biotec. Do not lift the instrument by the touchscreen, the CentriCult Unit, peristaltic pump unit, or the magnet unit.

 **CAUTION**

Ergonomic hazard. If the instrument is lifted by one person, there is the risk of personal injury. The transport should be performed by at least two people according to the instructions in section 4.5.2 "Transport". The instrument should be lifted in an upright position under each of the four corners at the base of the instrument.

Before transportation, the instrument must be switched off and disconnected from the power supply. All bag hangers and disposables should be removed from the instrument.

 **WARNING**

Chemical and biological hazard. Risk of chemical or biological hazards due to contaminated surfaces. If the instrument needs to be shipped back to the manufacturer for service, decontaminate the instrument from any hazardous material prior to shipment. For details regarding proper decontamination refer to the instructions in section 4.6 "Cleaning and disinfection".

3.2 Position of safety symbols

Notice the positions of the safety symbols (see Figure 3.1 and Figure 3.2) on the CliniMACS Prodigy and keep them in an easily readable state. The safety labels must be kept clean and legible.

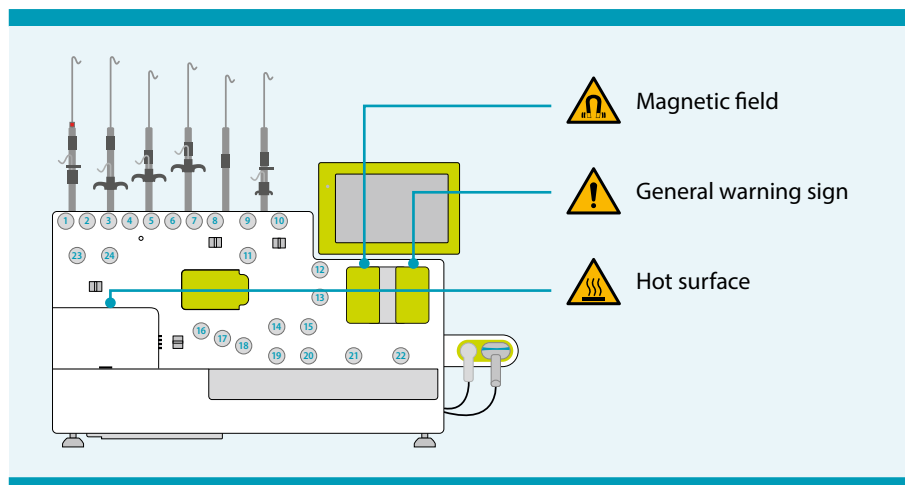

Figure 3.1: Position of safety symbols on the front of the instrument (exemplary SN 491 or higher)

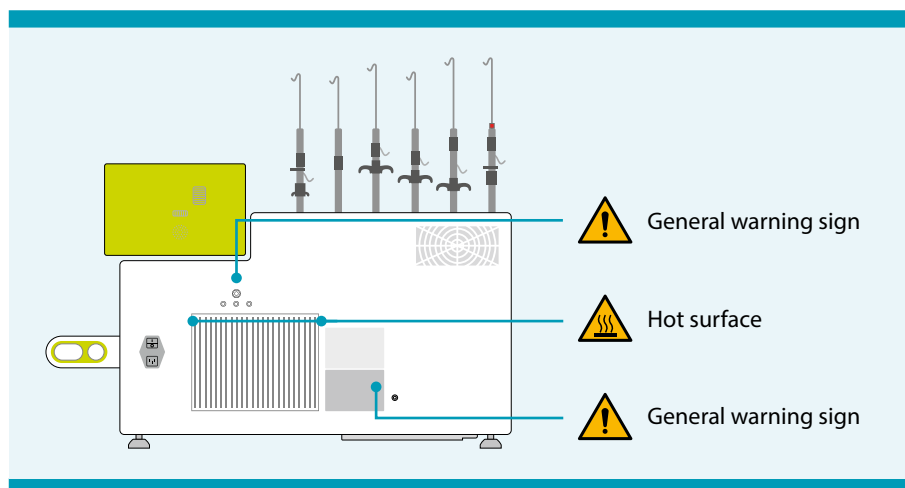

Figure 3.2: Position of safety symbols on the rear of the instrument (exemplary SN 491 or higher)

4

The CliniMACS Prodigy

4.1 Regulatory information

Based on the respective intended use, the CliniMACS Prodigy can be used in various application systems that differ in terms of their regulatory classification:

1. The **CliniMACS Prodigy Cell Separation System** is intended to separate human cells.
 - ▶ **CliniMACS Prodigy is a Medical Device in Europe if used as part of the CliniMACS Prodigy Cell Separation System.**
2. The **CliniMACS Prodigy Cell & Gene Therapy Manufacturing System** is intended for genetic and/or other substantial manipulation (like proliferation, differentiation) steps of human cells.
 - ▶ **CliniMACS Prodigy is no Medical Device in Europe if used as part of the CliniMACS Prodigy Cell & Gene Therapy Manufacturing System.**

For U.S. CAUTION: Clinical Research System Limited by Federal (or United States) Law to Investigational Use or under an FDA Approval

4.1.1 The CliniMACS Prodigy within the CliniMACS Prodigy Cell Separation System

Intended purpose

The CliniMACS Prodigy Cell Separation System, consisting of the components CliniMACS Prodigy, CliniMACS Reagent(s), CliniMACS Prodigy Tubing Set, CliniMACS PBS/EDTA Buffer, and further accessories, which must be used in combination, is intended for the *in vitro* separation of specific human cells for clinical applications.

The CliniMACS Prodigy is intended to operate the components of the CliniMACS Prodigy Cell Separation System to enable the *in vitro* separation of specific human cells for clinical applications.

For the operation of the CliniMACS Prodigy Cell Separation System, only the components stated as CE-marked medical devices and accessories defined in the CliniMACS Prodigy user manual for the respective applications must be used with and connected to the instrument.

The instrument conforms to the Medical Device Regulation MDR (EU) 2017/745:



The instrument complies with the following standards:

- IEC/EN 61010-1
- CAN/CSA-C22.2 No. 61010-1
- K 61010-1
- IEC/EN 61010-2-10
- CAN/CSA-C22.2 No. 61010-2-10
- IEC/EN 61010-2-20
- CAN/CSA-C22.2 No. 61010-2-20
- IEC 60601-1-2

For the applied standard version, refer to the respective Certificate of Conformance.

The instrument is in conformity with Directive 2011/65/EU of the European Parliament and of the Council of 8 June 2011 on the restriction of the use of certain hazardous substances in electrical and electronic equipment.

IMPORTANT

Any serious incident that has occurred in relation to this product should be reported to Miltenyi Biotec B.V. & Co. KG – using the contact information provided – and the competent authority of the member state in which the user of this product is established.

4.1.2 The CliniMACS Prodigy within the CliniMACS Prodigy Cell & Gene Therapy Manufacturing System

Intended use

The CliniMACS Prodigy Cell & Gene Therapy Manufacturing System is intended for *ex vivo* genetic and/or substantial manipulation of human cells or manufacture of an Advanced Therapy Medicinal Product (ATMP) for clinical applications.

Rationale

During applications of the CliniMACS Prodigy Cell & Gene Therapy Manufacturing System, the cells are subjected to modification (genetic and/or substantial manipulation; Cell separation, concentration, or purification are not considered as substantial manipulation according to Regulation (EC) No. 1394/2007) by pharmacological, immunological, or metabolic means as the principal intended action. The resulting cells are therefore considered as Advanced Therapy Medicinal Product (ATMP) in Europe.

As a consequence, the components of this CliniMACS Prodigy Cell & Gene Therapy Manufacturing System cannot be classified as Medical Devices. Instead, the CliniMACS Prodigy Cell & Gene Therapy Manufacturing System is considered as manufacturing system for medicinal products. Therefore, European GMP guidelines (EudraLex Vol. 4) have to be followed when using the CliniMACS Prodigy Cell & Gene Therapy Manufacturing System for manufacture of medicinal products in Europe.

For operating the CliniMACS Prodigy Cell & Gene Therapy Manufacturing System, only the stated products defined in the respective applications must be used with and connected to the CliniMACS Prodigy.

4.2 Technical data

WARNING

Safety and performance of the CliniMACS Prodigy may be compromised. Safety and performance of the instrument may be compromised if the CliniMACS Prodigy is used outside its specifications. Do not use the instrument outside its specifications.

The technical data of the instrument are listed in Table 4.1.

Technical data	
Model	CliniMACS Prodigy
Dimensions	Width: 73.2 cm (plus approx. 20 cm for holder of heat sealer and bar code reader) Depth: 40 cm housing Height: 48 cm housing (plus 42–60 cm for bag hangers)
Weight	Approx. 70 kg (excluding weight of attached consumables and accessories)
Input voltage	100–240 V AC (Single phase alternating current)
Power consumption	810 VA
Frequency	50/60 Hz
Fuses	2× T10AH250V
Pump speed	2–400 mL/min
Atmosphere control	Gas mix unit for CO ₂ , compressed air, and optionally N ₂ , min. pressure: 1.0 bar, max. pressure: 2.5 bar
Temperature control	+4 to +38 °C (+39 to +100 °F)
Centrifugation	Max. 2.500 rpm (400×g)
Microscope camera	Max. magnification 400-fold
Operation conditions	Temperature: +15 to +25 °C (+59 to +77 °F) Humidity: 10% to 75% relative humidity, non-condensing Altitude: <2,000 meters above sea level
Storage conditions	Room temperature Avoid condensing conditions.

Table 4.1: Technical data of the CliniMACS Prodigy

The instrument including accessories complies to the EMC standard IEC 60601-1-2. For details refer to the appendix of this user manual. It is a Protection Class I instrument and must be plugged into a grounded power outlet. Conditions of operation: Supply voltage fluctuations up to $\pm 10\%$ of the nominal voltage. Transient over-voltages present on the mains supply: Category II. The instrument is suitable for rated pollution degree 2.

The instrument has been tested and found to comply with the limits for a Class A digital device, pursuant to Part 15 of the FCC Rules. **Note:** The emissions characteristics of this instrument make it suitable for use in industrial areas and hospitals (CISPR 11 class A). If it is used in a residential environment (for which CISPR 11 class B is normally required), this instrument might not offer adequate protection to radio-frequency communication services. The user might need to take mitigation measures, such as relocating or reorienting the instrument. If this instrument does cause harmful interference to radio or television reception, which can be determined by turning the instrument off and on, the user is encouraged to try to correct the interference by one or more of the following measures:

- Reorient or relocate the receiving antenna,
- Increase the distance between the instrument and the receiver,
- Connect the instrument to an outlet on a circuit different from that to which the receiver is connected,
- Consult the dealer or an experienced radio/TV technician for help.

Changes or modifications of the instrument, unless expressly approved by Miltenyi Biotec, may void the authority to operate the instrument pursuant to FCC 47 CFR.

4.3 Components of the CliniMACS Prodigy

The following section describes the components of the CliniMACS Prodigy. Table 4.2 gives an overview of components included per instrument serial number. Repairs or hardware updates made by the authorized local Miltenyi Biotec Service Provider may lead to a modified state of construction and retrofitting of the instrument.

Serial number	001-490	491-xxx
Housing with		
• Bag hangers	6	6
• Bag hanger hooks	2 / Optional: 5	5
• Lower hook bag hanger A	- / ○	●
• Bag compartment(s)	●	●
Monitor		
• TFT Touchscreen	8.4"	10.1"
• USB port on monitor	1	2
• Touchscreen operated with blunt items	●	-
• Touchscreen operated with fingers/gloves	●	●
Peristaltic pump	●	●
Magnet unit	●	●
CentriCult Unit		
• with Layer Detection Camera and Microscope camera	●	●
• Drive shaft ready for CentriCult Chamber 800/1	-	●
Gas mix unit with gas outlet connector, gas inlet connectors, and safety valve	●	●
Sensors		
• Liquid sensors	4	4
• Pressure sensors	2	2
Pinch valves	24	24
Connector panel	●	●
Single pre-column holder	●	-
Dual pre-column holder	-	●

Caption: ● Standard ○ Optional - Not available

Table 4.2: Configuration differences of the instrument

The front view of the instrument is shown in Figure 4.1.

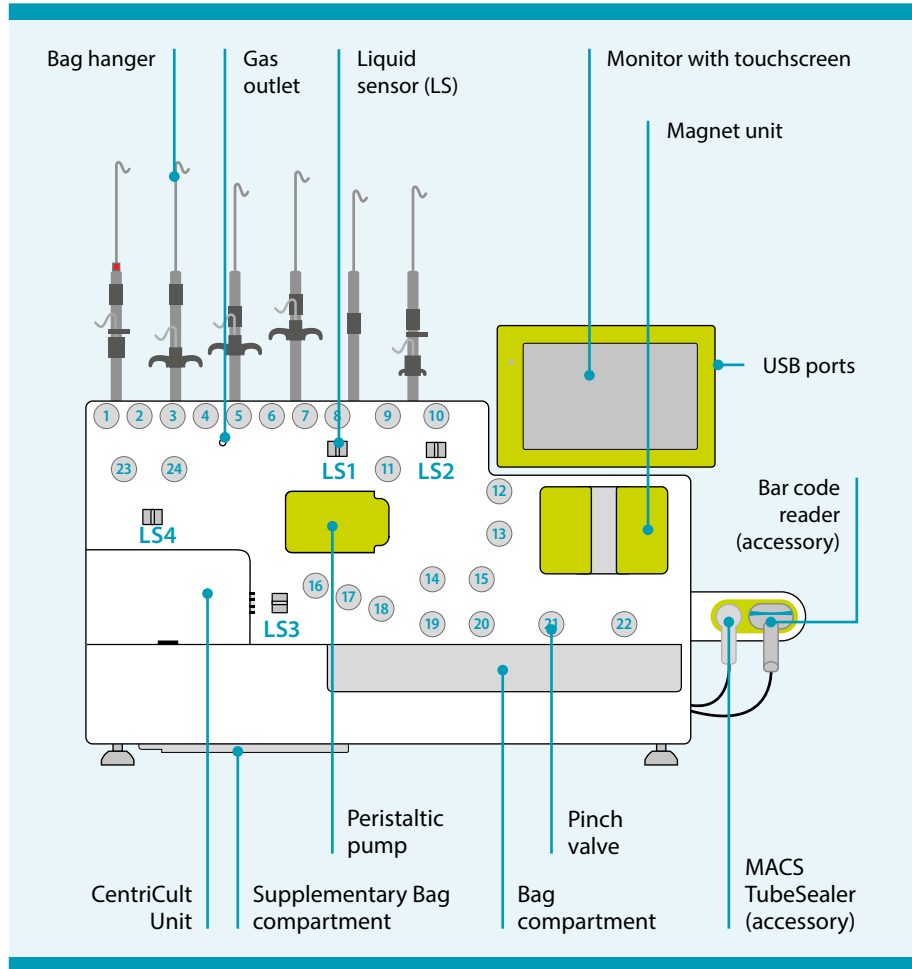

Figure 4.1: Front view of the instrument (exemplary SN 491 or higher)

The rear view of the instrument is shown in Figure 4.2.

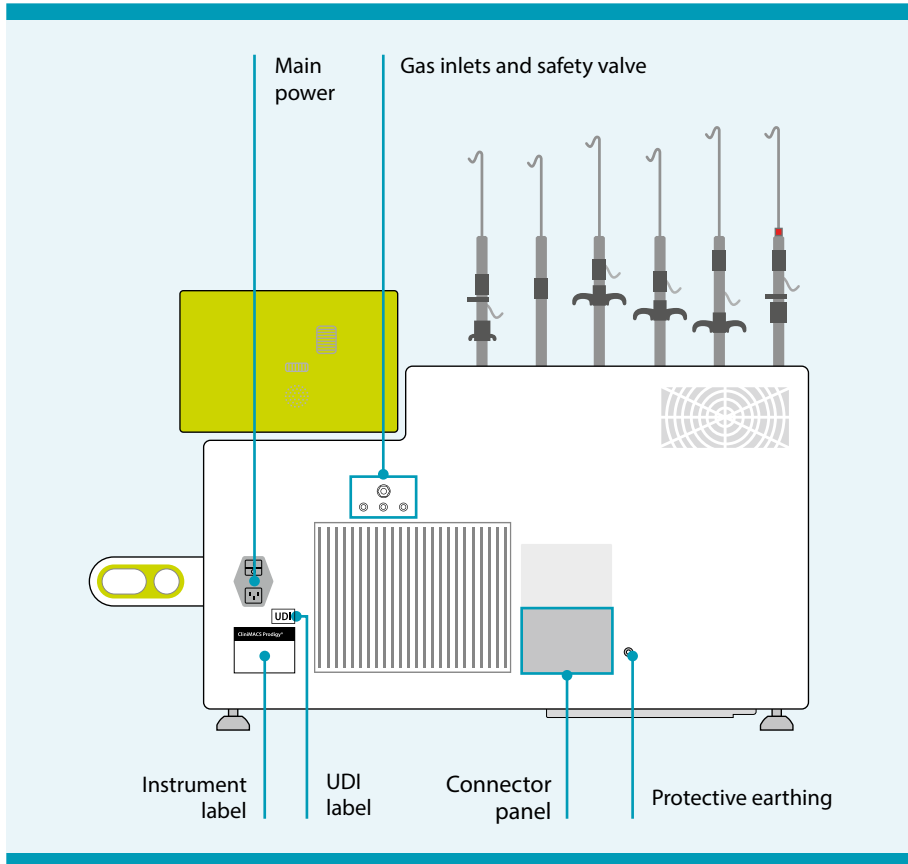

Figure 4.2: Rear view of the instrument (exemplary SN 491 or higher)

4.3.1 Housing and bag hangers

In addition to its common function as a cabinet, the housing also includes a set of bag hangers and a bag compartment that holds bags for fluids (e.g., waste bags). The touchscreen is also connected to the housing.

The CliniMACS Prodigy is equipped with six bag hangers labeled A to F at the top of the instrument (see Figure 4.3). An individual bag hanger is comprised of a rod, a spring loaded pinch clamp with a hook from which bags can hang, and additional supports, such as vial holders and pre-column holders. The pinch clamp allows for individual adjustment of the hook height. **NOTICE!** Risk of damage to the bag hangers in case of overloading. The carrying capacity of a single bag hanger is 5 kg. Do not overload the bag hangers.

Additionally, bag hanger A is equipped with a signal lamp to indicate the status of the instrument in operation and to provide optical warning signals when required. The signal lamp is a part of the alarm management system, described in detail in section 5.5 “Alarm management”. In addition, bag hangers A and F are equipped with the clamping fixture to hold the tubing set straps.

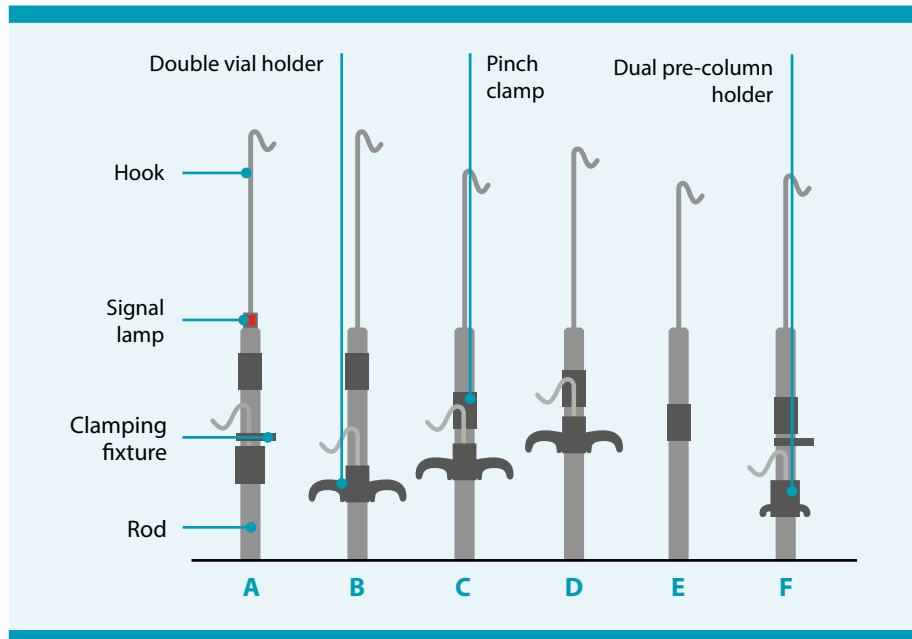

Figure 4.3: Bag hanger set mounted on the instrument

4.3.2 Monitor

The user interface is operated via touchscreen and manages all functions of the CliniMACS Prodigy. Usage of the touchscreen is possible when wearing surgical gloves. The touchscreen guides the operator through the setup procedure and allows monitoring of the instrument during operations. The monitor unit holds an internal speaker for acoustical signaling and alarm functionality. The integrated USB ports allows for easy data import and export (see Figure 4.1).

4.3.3 Peristaltic pump

The peristaltic pump is used to advance the liquids through specific flow pathways of the tubing set. A set of guide pins ensures the pump tubing stays in place. The pump has a rotational speed sensor and a rotor position detection. If the protection cover lid is open, the pump stops working. Do not open the protection cover of the pump during operations unless prompted by the graphical user interface. Integrated into the pump housing are two pressure sensors for measuring the pressure within the tubing set. For the individual components of the peristaltic roller pump (see Figure 4.4). The protection cover is not shown in the diagram.

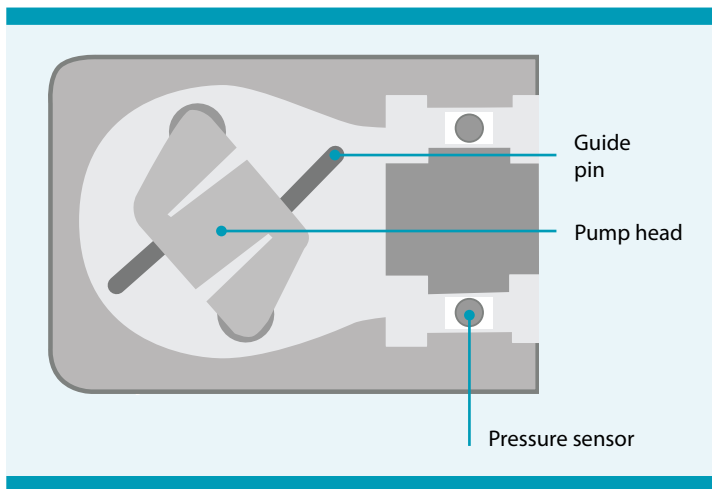

Figure 4.4: Components of the peristaltic pump

4.3.4 Magnet unit

The magnet unit induces a magnetic field into the separation column in order to separate magnetically labeled cells from non-labeled cells. This unit includes the movable, permanent magnet and a holder for the separation column (see Figure 4.5). A linear motor with position sensors is used to place the magnet in the ON and OFF positions. Inside the separation column, a strong inhomogeneous magnetic field is created which retains magnetically labeled cells within the column.

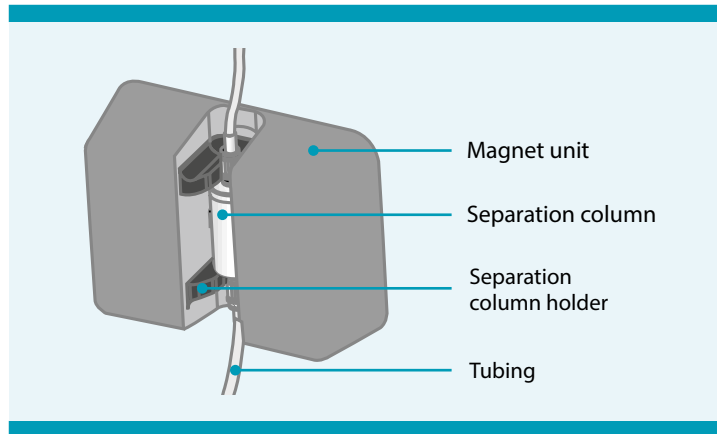

Figure 4.5: Magnet unit with separation column

4.3.5 CentriCult Unit

The CentriCult Unit is a functional unit for cell processing and cell cultivation purposes. The main components of this unit are the chamber drive unit, heat exchange unit, Layer Detection Camera, microscope camera, and a lid which tightly closes the CentriCult Unit (see Figure 4.6).

The chamber of the tubing set is attached to the chamber drive unit via the chamber lock adapter inside the CentriCult Unit. The centrifugation speed is defined by the process and controlled by sensors. The maximum centrifugation speed does not exceed 2,500 rpm. The chamber drive unit only operates when the lid of the CentriCult Unit is closed. In the same way, the lid of the CentriCult Unit locks the unit and may only be opened after the chamber drive has stopped. **Note:** The lid can only be opened and closed when prompted by specific process instructions, automatically or via the **open lid** button, if active, or via the settings menu between processes.

The Layer Detection Camera utilizes proprietary technology for the detection of different interlayers (e.g., plasma and cells) during centrifugation, allowing controlled aspiration of cells or fluids.

The CentriCult Unit is temperature controlled by the temperature control unit which is used to perform heating and cooling. It consists of a heat exchange unit, peltier elements, fans, and temperature sensors including an infrared sensor which is positioned in front of the chamber lock adapter (not visible in Figure 4.6).

An additional microscope camera (magnification up to 400-fold) is used for microscopic evaluation of cells cultivated in the chamber of the tubing set. Positioning of the chamber and focusing of the lens is performed via the graphical user interface.

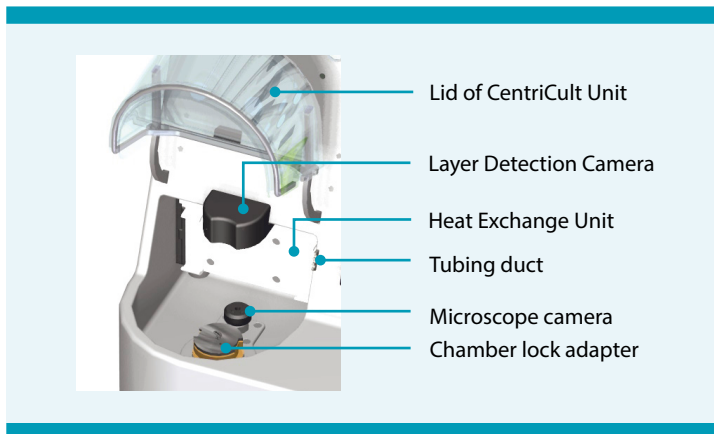

Figure 4.6: Components of the CentriCult Unit

4.3.6 Gas mix unit

It enables the preparation of a mixture of up to three different gases for cell culture purposes. Located at the back of the CliniMACS Prodigy are three gas inlets with 4 mm push-in connectors for CO₂, N₂, and compressed air plus a safety valve (see Figure 4.2 and Figure 4.7).

⚠ WARNING

Risk of gas emission or process failure. Risk of gas emission or process failure if excessive pressures are applied. Pressures of 1 bar to max 2.5 bar for each gas may be applied. The mixture ratio of these gases is controlled by the software and then passed into the tubing set through a gas outlet connector at the front of the instrument (see Figure 4.1). Only CO₂, compressed air, and optionally N₂ shall be used with the instrument. The safety of the gas supply system is the responsibility of the user.

For a detailed description of how to apply the necessary gas connections and required settings, refer to the appropriate CliniMACS Prodigy user manual (U.S. Edition) for the respective application which involves the gas mix unit. Only connect gases used in the desired process.

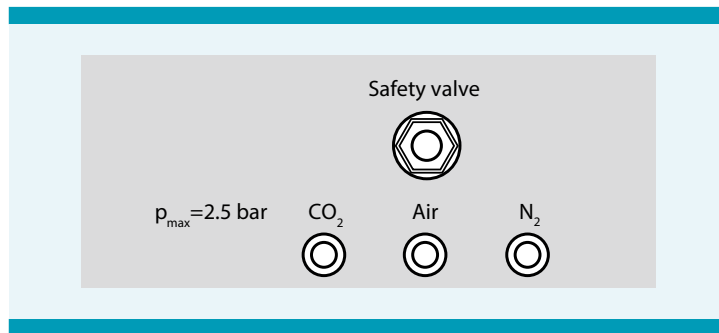

Figure 4.7: Gas inlet connectors and gas safety valve

4.3.7 Sensors

A variety of sensors, such as pressure sensors and liquid sensors, are used to control the process and verify correct user handling. The pressure sensors monitor the pressure within the tubing set to allow detection of leakages or clogging within the tubing set. These pressure sensors are an integral part of the pump housing (see Figure 4.4). Four liquid sensors at the front of the instrument (see Figure 4.1) monitor the flow of liquid within the tubing set based on an ultrasonic principle which allows detection of air bubbles within certain parts of the mounted tubing set. Specific process steps are designed so that disruption of continuous fluid flow through these sensors automatically advances the process to the next phase. Additional sensors include the temperature sensors for controlling the temperature of the CentriCult Unit and positioning sensors for controlling parameters such as the position and speed of the chamber or peristaltic roller pump. The temperature sensors also include an infrared sensor which measures the temperature directly at the bottom of the centrifugation and cultivation chamber.

4.3.8 Pinch valves

In total, 24 magnetic pinch valves can be used during operation to ensure controlled flow pathways within the tubing set. Additionally, the valves fix the tubing on the front plate of the instrument.

4.3.9 Connector panel

⚠ WARNING

Safety and performance of the instrument may be compromised. Safety and performance of the instrument may be compromised if non-authorized accessories, transducers, and cables are used. Only accessories, transducers, and cables, authorized by Miltenyi Biotec for the use in combination with the CliniMACS Prodigy, are allowed to be plugged into any of the connectors of the connector panel or any other connector socket of the instrument. This also includes USB devices.

⚠ WARNING

Risk of improper operation due to increased electromagnetic emissions or decreased electromagnetic immunity. The use of consumables, accessories, transducers, and cables other than those specified or provided by the manufacturer of this equipment could result in increased electromagnetic emissions or decreased electromagnetic immunity of this equipment, and thus lead to improper operation. Only use the instrument with accessories, transducers, and/or cables approved by Miltenyi Biotec. Refer to section 4.4.

CliniMACS Prodigy manufactured as of November 2020

A connector panel with connectors for input and output connections is positioned at the rear side of the instrument (see Figure 4.8). There are three USB ports for data input and output functionalities.

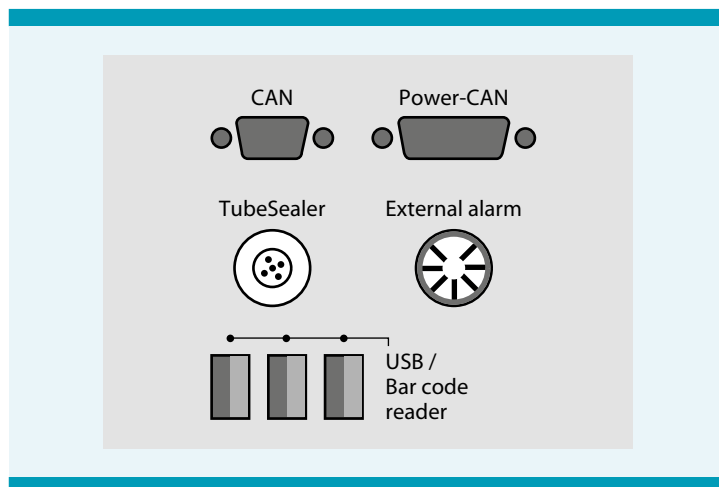

Figure 4.8: Connector panel (as of November 2020)

The alarm connector is used for connecting an external alarm system. A relay circuit provides 2 levels of information (see Figure 4.9); one for warning information (Relay 2) and another for a critical alarm situation (Relay 1). All other sockets (“CAN”, and “Power-CAN”) may be used for service purposes.

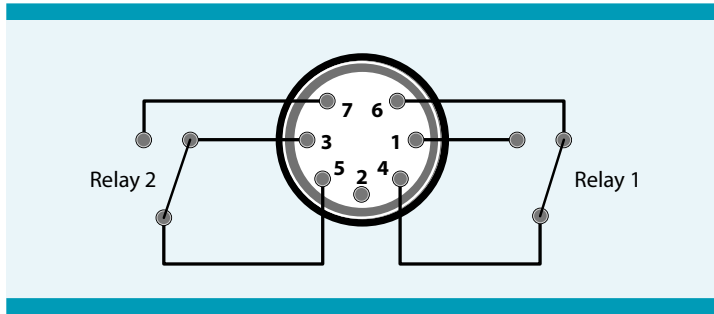

Figure 4.9: Relay circuit of alarm connector showing the idle state

CliniMACS Prodigy manufactured until October 2020

A connector panel with connectors for input and output connections is positioned at the rear side of the instrument (see Figure 4.10). There are three USB ports for data input and output functionalities. The AUX 5 pin socket is used for the MACS TubeSealer. The alarm connector is used for connecting an external alarm system. A relay circuit provides 2 levels of information (see Figure 4.9); one for warning information (Relay 2) and another for a critical alarm situation (Relay 1). All other sockets (“AUX, 3 pin”, “CAN”, and “Power-CAN”) may be used for service purposes.

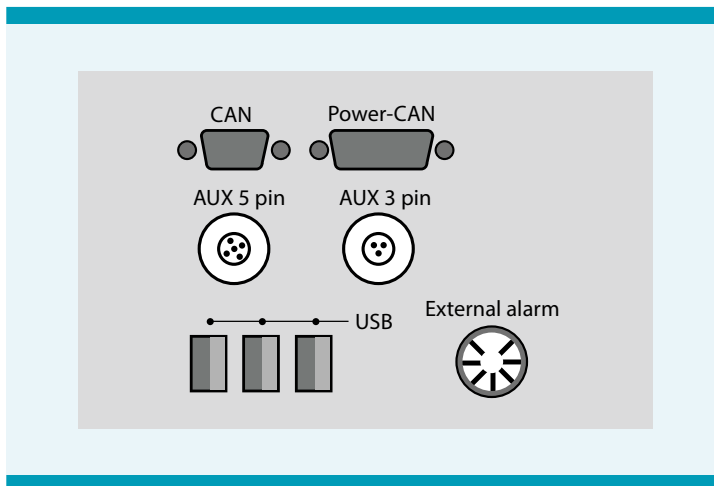

Figure 4.10: Connector panel (until October 2020)

4.4 Accessories for the CliniMACS Prodigy

The approved accessories, specified by the Miltenyi Biotec part number or by technical specification, are listed in Table 4.3.

Material	Comment
MACS TubeSealer	–
Bar code reader	Zebra DS4308-HC, DS4608-HC, or equivalent
CliniMACS Prodigy Supplementary Bag	–
CliniMACS Electroporator (optional)	–
CliniMACS Formulation Unit (optional)	–
USB to Ethernet adapter	–
Ethernet cable to connect the Ethernet adapter	Cat5 or higher
External alarm cable	Shielded cable

Table 4.3: List of accessories, transducers, and cables authorized to connect to the instrument

4.4.1 MACS TubeSealer

The MACS TubeSealer is used for sealing PVC and EVA tubing of the CliniMACS Prodigy Tubing Sets installed on the CliniMACS Prodigy. A detailed description of the MACS TubeSealer and relevant safety information are provided in the MACS TubeSealer user manual (U.S. Edition). The MACS TubeSealer must be connected to the instrument via the TubeSealer port at the rear side of the instrument (see Figure 4.8).

4.4.2 Bar code reader

The bar code reader is intended to scan bar codes printed on, e.g., CliniMACS Materials, required for process execution with the CliniMACS Prodigy System. The scanned data serve as input of part numbers and batch codes of the CliniMACS Materials required for an application. These numbers and any other process-related parameters may also be entered manually. The bar code reader can be connected to any USB port of the CliniMACS Prodigy. For handling reasons, it is recommended to connect the bar code reader to one of the three USB ports at the rear of the instrument (see Figure 4.8).

4.4.3 CliniMACS Prodigy Supplementary Bag

The CliniMACS Prodigy Supplementary Bag is intended to help reduce the user's contact to potentially infectious sample material which may be accidentally emitted out of the CliniMACS Prodigy Tubing Set. In case of a malfunction – especially a chamber leakage– liquid might leak into the enclosed CliniMACS Prodigy housing and will be collected inside the removable Supplementary Bag which can be disposed of easily. The Supplementary Bag is placed within the Supplementary Bag compartment underneath the CentriCult Unit (see Figure 4.1). Fluids accidentally leaking out of the Chamber into the CentriCult Unit are collected in the bag. The CentriCult Unit can then be cleaned and the bag must be replaced by a new one. For instructions regarding the replacement of the bag, refer to the instructions for use provided with the bag.



It is recommended to replace the Supplementary Bag no later than one year after it has been installed onto the instrument, considering not to exceed the use-by date. Therefore, the installation date must be written onto the Supplementary Bag label beside the calendar symbol.

4.4.4 CliniMACS Electroporator

The CliniMACS Electroporator is a fully automatic instrument for the electroporation of eukaryotic cells in combination with the CliniMACS Prodigy. After electroporation, cells are further processed by the CliniMACS Prodigy. The CliniMACS Electroporator is connected to the CliniMACS Prodigy. The electroporation takes place in the electroporation cuvette. The electroporation cuvette is part of CliniMACS Prodigy Tubing Sets and is placed in the electroporation unit of the CliniMACS Electroporator.

Different types of eukaryotic cells can be electroporated. This technique allows the transfection of cells with nucleic acids, proteins or other small molecules. The CliniMACS Electroporator is intended to be used in combination with the following components: CliniMACS Prodigy, CliniMACS Reagents, CliniMACS Prodigy Tubing Sets, CliniMACS PBS/EDTA Buffer (3000 mL), and CliniMACS Electroporation Buffer. Refer to the CliniMACS Electroporator user manual for further information.

4.4.5 CliniMACS Formulation Unit

The CliniMACS Formulation Unit is an instrument accessory for the automated final formulation and sampling of eukaryotic cells in combination with the CliniMACS Prodigy. The CliniMACS Formulation Unit enables the user to take cells during or after processing by the CliniMACS Prodigy. The CliniMACS Formulation Unit is mounted onto the bag compartment of the CliniMACS Prodigy and powered by the CliniMACS Prodigy via the Power-CAN connector. Refer to the CliniMACS Formulation Unit user manual for further information.

4.5 Unpacking and installation

CAUTION

Risk of damage to the CliniMACS Prodigy. Risk of damage to the instrument if the instrument is unpacked or installed by unauthorized persons. Unpacking and installation of the instrument must only be performed by an authorized local Miltenyi Biotec Service Provider. Read chapter 3 “Important safety information” before installation and use of the instrument. Visually inspect and note any significant damage to the package. Damage may require inspection by a representative of the shipping company.

4.5.1 Scope of supply

The content of supply is:

- One CliniMACS Prodigy
- One power cord (country specific)
- Six bag hangers equipped with specific mounting supports, one bag hanger is additionally equipped with an LED lamp
- Accessories: MACS TubeSealer, bar code reader, two CliniMACS Prodigy Supplementary Bags including instructions for use
- Holder (frame and inlay) for MACS TubeSealer and bar code reader
- Instructions for use for the CliniMACS Prodigy

4.5.2 Transport

WARNING

Risk of internal damage. Internal damage can occur if the instrument is subjected to excessive vibration or if it is dropped. The CliniMACS Prodigy should be transported with care in packaging specified by Miltenyi Biotec.

WARNING

Chemical and biological hazard. Risk of chemical or biological hazards due to contaminated surfaces. If the instrument needs to be shipped back to the manufacturer for service, decontaminate the instrument from any hazardous material prior to shipment. For questions regarding proper decontamination or shipment, contact Miltenyi Biotec Technical Support for assistance.

CAUTION

Ergonomic hazard or damage to the instrument. If the instrument is lifted by one person there is the risk of personal injury or damage to the instrument. The instrument should be lifted by at least two people. Do not lift the instrument by the monitor, CentriCult Unit, peristaltic pump, or magnet unit.

4.5.3 Positioning

WARNING

Electrical hazard. To avoid electrical hazards it must be possible to interrupt the power supply at any time. The power connection including the fuse holder and the main switch must be accessible at all times.

CAUTION

Risk of overheating. Risk of overheating in case of reduced air circulation. Do not place the instrument with the back side directly against the wall. Keep at least 14 cm distance to allow free air circulation. Allow sufficient space around the ventilation slots at the rear and underneath the instrument. Take into consideration that the instrument requires adequate air circulation for heat exchange and cooling. Read the chapter "Important safety information" to avoid the risk of overheating.

CAUTION

Risk of serious harm and/or serious damage to the instrument. The CliniMACS Prodigy could fall and cause serious harm and/or serious damage to the instrument. The instrument must be placed evenly on a flat and stable surface which is capable of supporting 100 kg and free of vibrational or other mechanical forces. Do not locate the instrument next to vibrating equipment which might cause movement during operation.

Noise level

If the instrument is used at maximum load, it might produce noise up to 63 dB(A). Ensure that alarm signals from other instruments are noticeable.

4.6 Cleaning and disinfection

WARNING

Risk of electric shock or damage to the instrument. Risk of electric shock or damage to the instrument if the CliniMACS Prodigy is cleaned with excessive amount of cleaning agent or while switched on. Only clean the instrument when it is switched off and the power cord is unplugged. Avoid ingress of any liquid into the valves and into the liquid sensor. Do not use an excessive amount of cleaning or disinfection agents to avoid spilling into the gas outlet connector. After cleaning, dry all excess liquid from the valves, pump head, gas outlet connector etc.

WARNING

Safety and performance of the instrument may be compromised. Safety and performance of the instrument may be compromised if other than the above mentioned cleaning methods are used. UV may damage plastic parts of the instrument. Do not use UV irradiation. The instrument should not be sterilized, e.g., with H₂O₂.

Clean the instrument with one of the following disinfectants, which are compatible with the surface of the instrument:

- Aldehyde up to 3%, e.g., Melsitt® 3% or Kohrsolin® FF 3%, or
- Ethanol up to 80%.

Dust off the valves, peristaltic pump, and magnet unit using a paper towel or absorbent material.

In case of contamination, e.g., due to leakage in the CentriCult Unit, see chapter 7 “Troubleshooting”.

IMPORTANT

The surface of the instrument, including the CentriCult Unit and the bag compartment, should be cleaned at regular intervals and after each application. Cleaning after unpacking and installation is also recommended.

4.7 Maintenance

WARNING

Hazard to users, unpredictable results, instrument malfunction or damage, premature wear and reduced life time of the instrument. Improper or incorrect servicing or repair of the instrument can cause hazards to users, lead to unpredictable results, instrument malfunction or damage, premature wear and reduced life time of the instrument, and may void the warranty. Unless otherwise specifically noted in this user manual, do not service the CliniMACS Prodigy. Service and repair may only be performed by authorized local Miltenyi Biotec Service Provider. Routine and preventative maintenance procedures should be conducted by the manufacturer's authorized service personnel at least once a year.

The CliniMACS Prodigy does not require any form of calibration. Contact the authorized local Miltenyi Biotec Service Provider for instrument service and support arrangements.

4.8 Disposal



Contact Miltenyi Biotec Technical Support for final disposal. The CliniMACS Prodigy must be separately collected according to the European directive of waste of electrical and electronic equipment (WEEE). For final disposal, the instrument must be returned to the manufacturer. Clean the instrument according to the instructions given in section 4.6. The instrument should be transported with care in packaging specified by Miltenyi Biotec.

WARNING

Biological hazard. If the instrument is transported without prior disinfection there is the risk of infection. Clean and disinfect the instrument according to the instructions given in section 4.6.

5

The CliniMACS Prodigy Software

The CliniMACS Prodigy Software allows the operator to choose between processes and user programs and control certain instrument functionalities. The following notations are used to describe software elements:

- Text in **gray** indicates elements available for selection (e.g., press buttons),
- Text in **light green** indicates dialog boxes.

5.1 Touchscreen

5.1.1 Use of touchscreen

The CliniMACS Prodigy is equipped with a high-resolution touchscreen. All elements of the instrument software are operated via the touchscreen. Two simple gestures of fingers are detected by the touchscreen.

Press: A short contact of touchscreen elements with fingers is called a “press”. This gesture is used to start a process, to mark data, or to interact with a process during dialog control.

Hold: Contact and holding of a spot on the touchscreen will be detected as a gesture by some control elements (e.g., lists). This gesture is used for quickly scrolling through lists.

The touchscreen can detect gestures with gloved fingers.

5.1.2 General setup menu

After switching on the power of the CliniMACS Prodigy, the software starts up and the start screen appears for a short time (approx. 5 seconds).

The start screen provides information about the software version and the result of the initialization process. After the initialization process, the menu button **Processes** is selected automatically and within the list of processes, the first one is highlighted automatically.

5.2 Login, logout, and emergency stop

With software version 2.0, the software feature “Application Services” has been introduced. These services comprise the 21 CFR Part 11-supporting functionalities “Audit Trail” and “User Management” (see section 5.4) including an authentication procedure. Consequently, a login is required by any user who wants to interact with the instrument.

In software version 2.0, two new dynamic buttons were introduced, a **Login** button which is positioned in the upper right corner of the screen and an **Emergency Stop** button in the lower left corner. Upon switching on the CliniMACS Prodigy, a locked screen will appear which has a darker color compared to an unlocked screen and which shows these two buttons (see Figure 5.1).

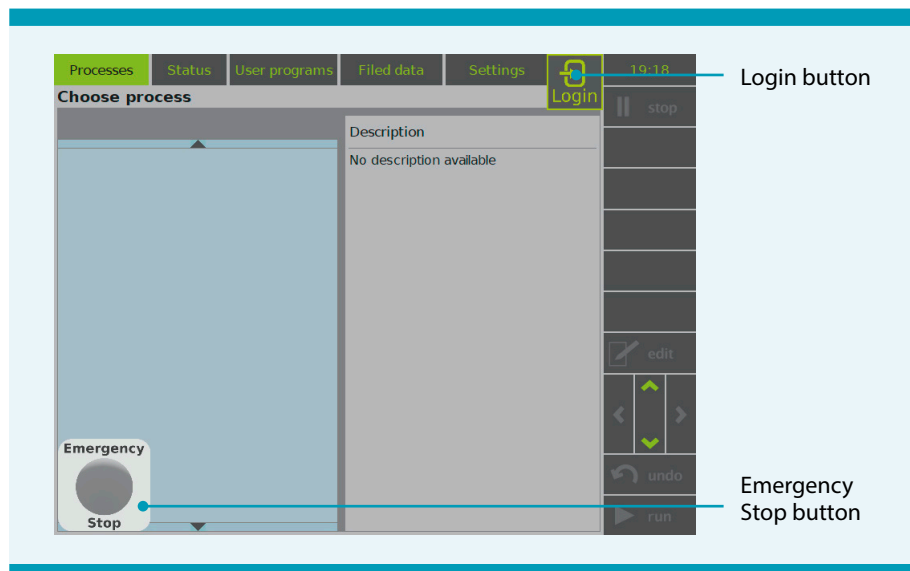

Figure 5.1: Locked starting screen

5.2.1 Login

To interact with the instrument, a user must login with the user name and password using the **Login** button in the upper right corner of the screen (see Figure 5.1). Pressing the button opens the pop-up window “User Login”. After entering user name and password and pressing **Login** within the pop-up window, the screen will unlock.

Note: If there is no interaction with the instrument for 20 minutes, the screen will be locked again showing the activated login button.

CAUTION

Risk of process failure if the instrument login is not possible anymore. In order to avoid such a situation, appropriate user and administrator accounts with distinct passwords need to be created before starting to run applications on the CliniMACS Prodigy. In addition, it is highly recommended to establish a so-called “break-glass solution” for emergency situations allowing the login for an individual user lacking sufficient access rights. This could be a closed envelope near the instrument containing user name and password of such an emergency account. Such a solution should be simple and quickly available without unreasonable administrative delay. In general, the authentication procedure should be described and implemented within the quality management system of the facility and all users and administrators need to be trained accordingly. In case an instrument login is not possible anymore, contact Miltenyi Biotec Technical Support.

5.2.2 Logout

If there is no interaction with the instrument required for a certain time period, a user can logout using the logout function within the **Application Services** menu (see Figure 5.3). The screen will then be locked again and the status screen will be shown.

5.2.3 Emergency Stop

The **Emergency Stop** functionality enables an immediate pause of a running application or a tool in case of an emergency situation when no user is logged in, without violating 21 CFR Part 11 requirements to the audit trail. In such a case, the software requests a reason for the emergency stop and a subsequent login. This information is then captured in the Audit Trail. The **Emergency Stop** button is only activated (indicated by the colors yellow and red) when an application or a tool is running and no user is logged in.

Note: The **Emergency Stop** does not completely switch off the instrument, it has the same function as the **stop** button during a running application when a user is logged in.

5.3 The graphic user interface

5.3.1 Operating controls

The display of the user interface is divided into several sections (operating controls) performing different tasks. During software operation, operating controls are adapted automatically to different process requirements. The basic operation controls are the menu bar, tool bar, and status line (see Figure 5.2). In addition, there are two or more windows which may be positioned differently according to the current status of a process or the active menu.

Note: The following figures are examples of the graphic user interface. Parts of the text presented on the screens in the user manual may differ slightly from the screens displayed on the instrument. The configuration of elements depends on the status of the process. With the continuous development of new processes and software features, additional content may be displayed on the instrument screens which may not always be shown in the following figures.

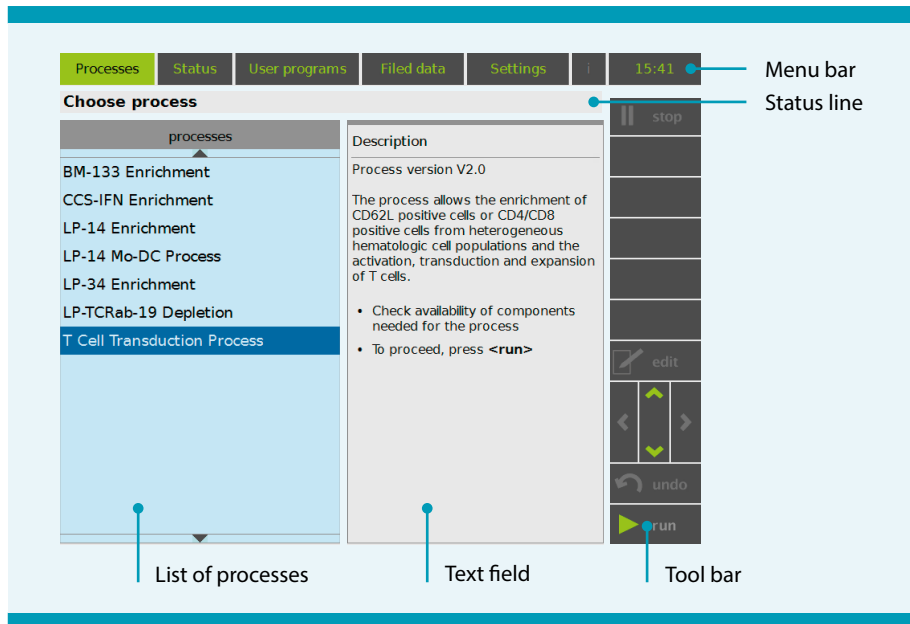

Figure 5.2: Operating controls (up to software version 1.4)

Menu bar

The software offers several menu buttons for different functionalities (see Figure 5.2). A menu is selected by pressing the respective menu button. A green background indicates which menu button is active. Depending on the current status of the software program, some menu buttons are not available for selection as indicated by a change of font color from green to gray. For details regarding menus (see section 5.3.2).

Note: As of software version 2.0, an additional menu button for the menu **Application Services** was added to the menu bar (see Figure 5.3).

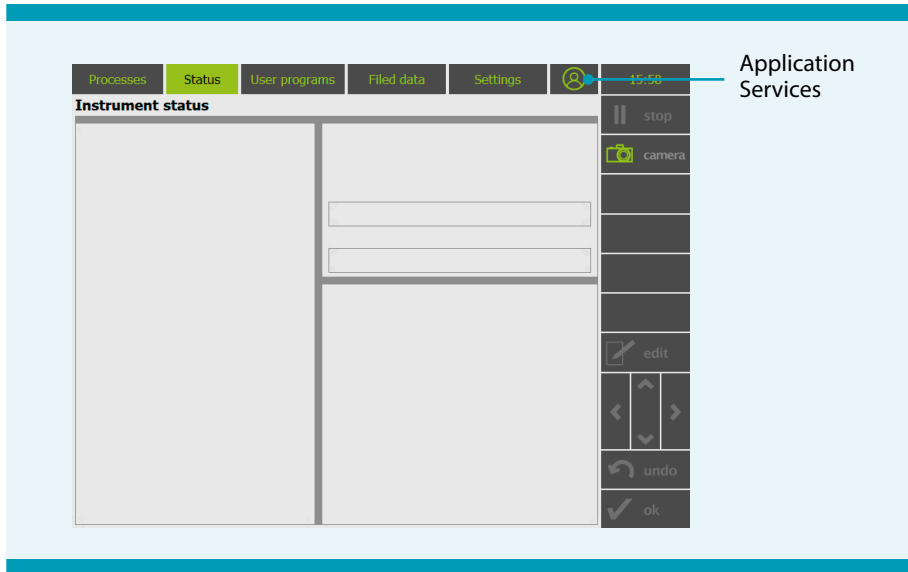

Figure 5.3: New Application Services button in menu bar as of software version 2.0

Lists

Lists consist of similar elements, e.g., list of processes (see Figure 5.2) or user programs. Each list element can be chosen and marked by directly pressing the element or by using the **up** and **down** navigation buttons of the tool bar. Holding the navigation buttons will quickly scroll through the list elements. A list is always shown in a window with light blue background color.

Status line

The status line (see Figure 5.2) contains brief information regarding the status of the current process.

Tool bar

The tool bar shows the changing functions of the touch buttons and is divided in a dynamic and static part. The static buttons of the tool bar are the **stop**, **navigation**, **undo**, **edit**, and **ok** buttons (see Figure 5.4). The wording of the **ok** button may change to **run** whenever a process or a program needs to be started.

Depending on the activated menu group, the dynamic part of the tool bar changes the appearance and functions of the touch buttons. The functions of the touch buttons in the static part remain unchanged and are independent of the selected menu group.

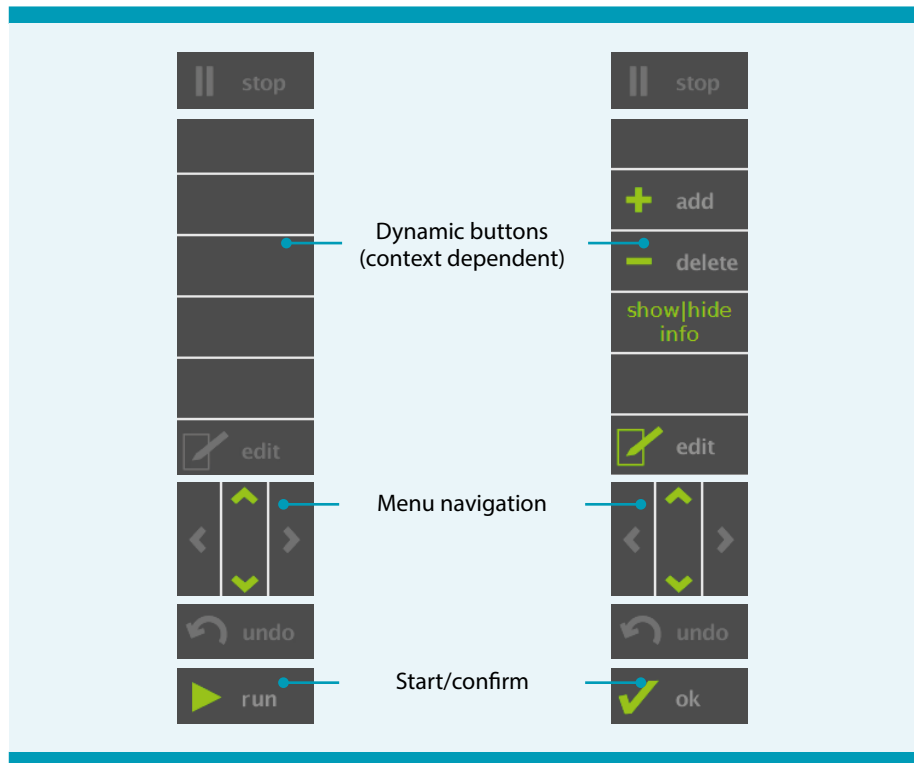

Figure 5.4: Dynamic and static buttons of the tool bar

Static buttons

The functions of the static buttons (see Figure 5.4) do not change with respect to the different menus. The only exception is the **ok** button which changes into a **run** button whenever there is a process, a user program, or any other procedure to be started.

- **Stop button**

The **stop** button is available in every menu group and can be used according to the status of a process. The **stop** button is active when showing a green symbol. This is the case when a process is running. When the active **stop** button is pressed, the process run will be interrupted. The font color of the stop button changes from green to gray to indicate that no process is running and the **stop** button is inactive.

- **Navigation buttons**

The **navigation** buttons are used to select elements from a list or navigate in images from the camera (see section 5.3.2).

- **Undo button**

The **undo** button enables the operator to revoke one or more inputs to restore the original content of the screen. The **undo** button is not active in all screens.

- **Ok/Run button**

Depending on the activated menu, pressing the **ok** button will confirm a selection by the operator or will close the active menu. The **ok** button turns into a **run** button whenever there is a process, user program, or any other procedure to be started.

- **Edit button**

The **edit** button activates the input field for manual data input when required.

Dynamic buttons

The functions of the buttons (see Figure 5.4) in the dynamic part will change according to the activated menu and the currently running application.

- **Open lid button**

The **open lid** button enables the customer to manually open the CentriCult Unit lid. This button is only visible and/or active according to the selected menu and status of the process running.

- **Save button**

The **save** button enables the operator to save a process protocol on a USB stick. The save functionality is only available in the **Filed data** menu.

- **Camera menu**

The **camera** button opens the camera menu (see section 5.3.2). The button is only available in processes enabling camera functionality.

Input fields

During a process, the operator may be asked to manually enter parameters such as names or numbers. An input field is displayed on the screen that represents the functionality of a keypad and allows for the input of letters or numbers (see Figure 5.5).



Figure 5.5: The input field – keypad with letters

For manual entry of capital letters, press **↑**, for space press **SP**, for numbers press **?123**, and for backspace press **⌫**.

5.3.2 Menus

Processes menu

After start up and initialization of the CliniMACS Prodigy Software, the menu **Processes** is selected automatically. The central element of this menu is the list of processes that can be performed (see Figure 5.2, left light blue-colored window). Individual processes may be selected by directly pressing on the process name or by using the navigation buttons. The text field (see Figure 5.2, right window) contains brief information regarding the selected process and its version number. Press the **run** button to start the selected process.

During a process run, additional control elements such as “instructions” or a “progress bar” are available. The availability of these control elements depend on the status of the process. These elements are explained in more detail in the application user manuals.

The displayed instructions tell the operator to carry out the actions required for a process (e.g., installation of the tubing set). Instructions are given in written form and, whenever possible, include corresponding schematic drawings to further explain the required actions. The progress bar shows the process name and the remaining time of the process running.

Status menu

The **Status** menu is opened by pressing the **Status** button. The status menu provides information regarding the operational state of the running process. When no process is running, the status screen is blank.

The status screen is grouped into the following elements:

- **Process-related parameters**
This element displays a list of all relevant process parameters. The list may contain up to 20 different parameters (see Figure 5.6, left window).
- **Info box and progress status**
This element (see Figure 5.6, upper right window) contains the operator’s name and information about the sample. It also contains two progress bars showing the progress of the process running. The lower progress bar shows the remaining time before the whole process is finished. The upper progress bar displays the remaining time of the subprocess running.

- **Graphic overview**

The graphic overview element (see Figure 5.6, lower right window) provides visual information about the running subprocess status of the instrument. All activities of the instrument components (peristaltic pump, pinch valves, etc.) are visualized in orange. In this menu, the tool bar offers additional functions.

The **stop** button may be used to interrupt the execution of the process. The **camera** button selects the subcamera menu (see section 5.3.2).

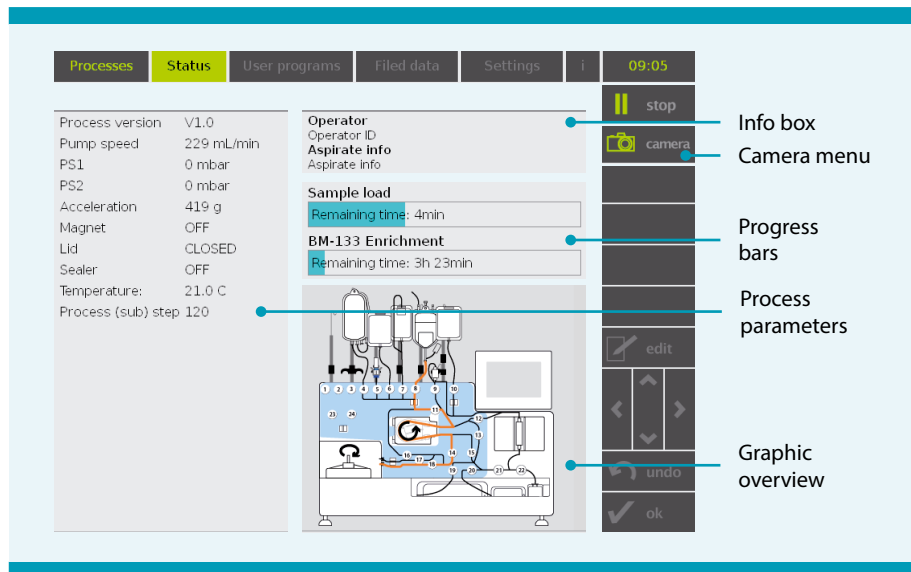

Figure 5.6: Overview of process status

Camera menu

There are two camera functionalities which can be selected by pressing the **camera** button within the menu group **Settings**. The first functionality shows images of the Layer Detection Camera during centrifugation. In addition, graphical information is provided about the volumes of the centrifugation fractions automatically detected by the Layer Detection Camera. The second camera functionality refers to images provided by the microscope camera. These two functionalities cannot be active at the same time. As a consequence, during some processes, the microscope camera may never be active.

Note: The camera menu is positioned within the menu group **Settings** and may be selected during a process by pressing the **camera** button in the tool bar. If the camera menu is not enabled, the **camera** button is gray and inactive.

Layer Detection Camera

The camera menu shows the last image saved by the Layer Detection Camera. Red and orange bars mark the position of the layers within the image. A diagram below the image continuously displays the recorded values for the volumes of the centrifugation fractions. The curves are displayed in red and orange corresponding to the bars within the image (see Figure 5.7).

The operator may use the following functionalities if enabled:

- Image recording:
If the **snap** button is active, pressing the button will prompt the camera to record a new image. After a short recording phase (approx. 15 seconds), the displayed image will be replaced by a newly recorded image.
- Image archiving:
The recorded image may be saved by pressing the **save** button. The recorded image will be integrated in the protocol of the current process.
- Quitting camera menu:
Quit the camera menu by pressing the **ok** button.

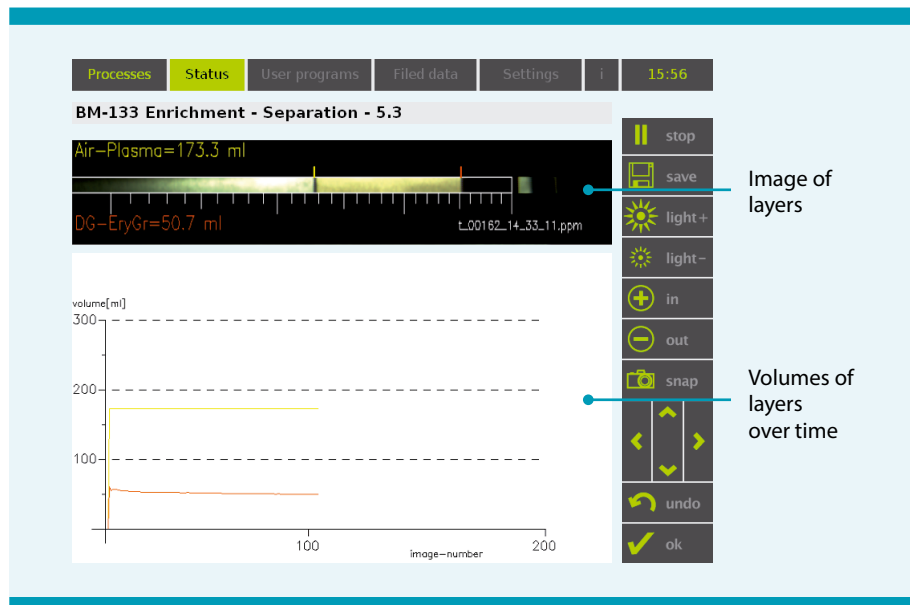

Figure 5.7: Status screen when Layer Detection Camera is active

Microscope camera

It is only active in processes with cell culture procedures. The magnification of the images is up to 400-fold. As with the Layer Detection Camera, the camera menu shows the last image saved by the integrated microscope camera (see Figure 5.8).

The operator may use the following functionalities if enabled:

- **Navigation within an image:**
Touching the image of the microscope camera will result in a 2-times magnification. The point of touch will be the new center of the image. The navigation buttons allow further navigation within the image. Pressing a navigation button will result in a shift by half a frame in the selected direction. Image roll bars show the absolute position of the image section in the whole image to facilitate the navigation. The last ten navigation steps can be undone separately by repeatedly pressing the **undo** button.
- **Image recording:**
If the **snap** button is active, pressing the button will prompt the camera to record a new image. After a short recording phase (approx. 15 seconds), the displayed image will be replaced by a newly recorded image.
- **Image archiving:**
The recorded image may be saved by pressing the **save** button. The recorded image will be integrated in the protocol of the current process.
- **Quitting camera menu:**
Quit the camera menu by pressing the **ok** button.



Figure 5.8: Status screen when microscope camera is active

User programs menu

The menu **User programs** offers space for generic, pre-installed programs as well as for customized tailor-made programs. Customized programs can be requested from the Miltenyi Biotec Customized Application (CAP) Service. This service offers individual programming of a customer specific protocol meeting specific user requirements. For more information, contact Miltenyi Biotec Technical Support.

The operator may choose from a list of user programs (see Figure 5.9, left window: the names listed here are examples of potential user program names). The text field (see Figure 5.9, right window) contains brief information regarding the selected user program.

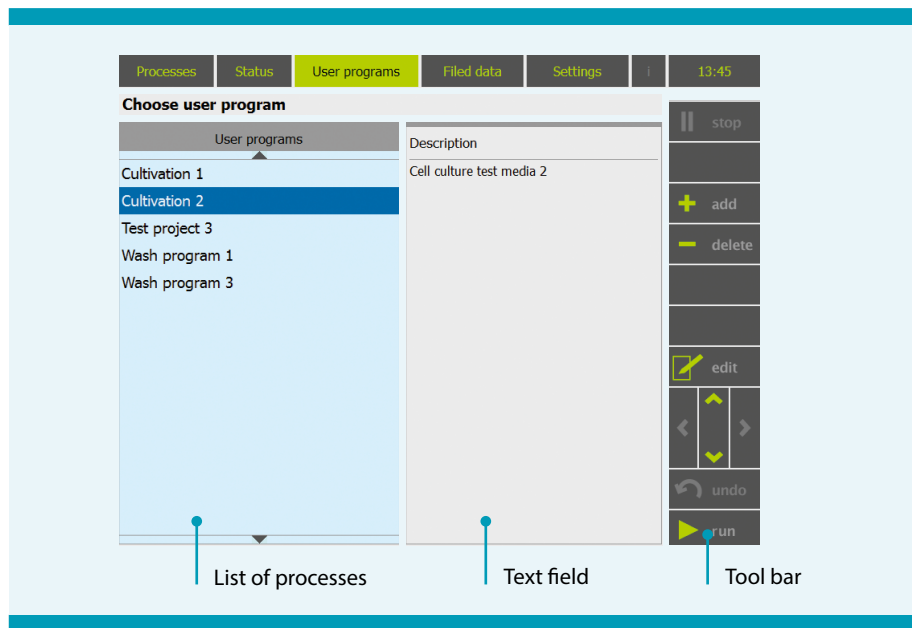

Figure 5.9: List of user programs

Filed data menu

The menu **Filed data** contains a list of protocols indicating all processes executed on the instrument. The list provides information regarding the relevant parameters of the individual process runs, for example, the date and duration of a process.

Note: The menu **Filed data** is not available during a process run. The respective touch button is inactive.

For each process, a protocol will be saved and stored within this menu (Figure 5.10). By selecting a process from the list, the respective protocol will be displayed by pressing the **ok** button. The displayed protocol may be saved as a PDF onto a USB stick by pressing the activated **save** button. The USB stick must be inserted into the USB port at the side of the touchscreen.

The screenshot shows a touchscreen interface with a top navigation bar containing 'Processes', 'Status', 'User programs', 'Filed data' (highlighted), 'Settings', and 'i'. The time '14:53' is displayed in the top right corner. Below the navigation bar, the title 'Process protocol' is shown. The main content area displays the following information:

Process protocol
BM-133 Enrichment

Aspirate info	bm3813
Start of process	2012-11-29 (09:45:29)
Completion of process	2012-11-29 (14:06:10)
Operator	Operator
Process Id	201211094529_BM-133 Enrichment

Material used

CD133 Reagent	70110 (PN) , 1234567891 (LOT)
Process Buffer Bag I	70025 (PN) , D0462 (LOT)
Process Buffer Bag II	70025 (PN) , D0467 (LOT)
TS 100	97181 (PN) , 5120813261 (LOT) , 2015-08 (Expiration Date)

Process information

Aspirate volume	113 ml
Used instrument	gubl, S/N: N/A

On the right side of the screen, there is a vertical toolbar with the following buttons: 'stop' (with a pause icon), 'save' (with a floppy disk icon), 'edit' (with a pencil icon), a set of four directional arrows (up, down, left, right), 'undo' (with a curved arrow icon), and 'ok' (with a checkmark icon).

Figure 5.10: Example of a process protocol

Settings menu

In the menu **Settings**, the operator will find additional programs for configuration and survey of the instrument. When the menu is selected, three columns are displayed. The active window is indicated by a light blue background color.

All programs in this menu are grouped in different categories (Option groups) that are listed in the left window. All programs contained in a category are listed in the middle window (Option programs). The right window (Program description) displays a text field where information about the selected program are indicated.

Categories and programs may be selected by directly pressing the selection or by using the navigation buttons. The navigation buttons **left** and **right** select the category and program lists. Navigation buttons **up** and **down** select the list elements.

Start a selected program by pressing run.

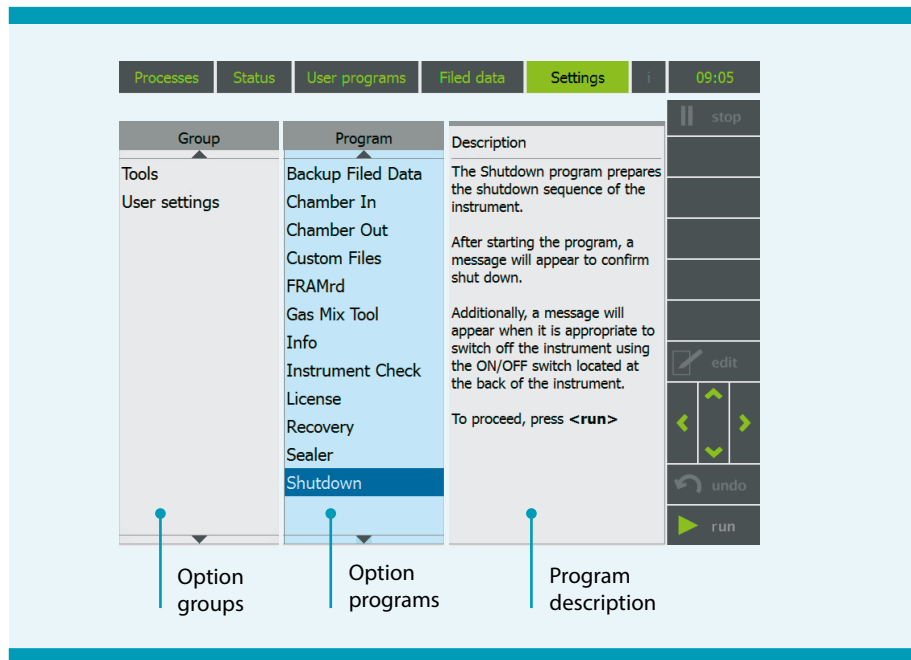
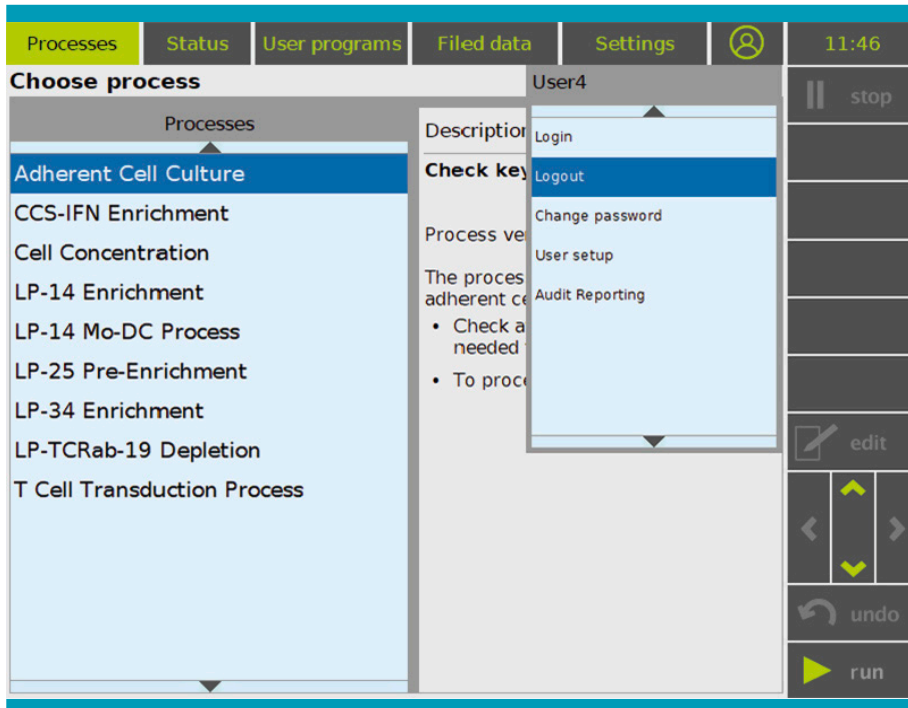

Figure 5.11: Menu "Settings"

5.4 Application Services

With the CliniMACS Prodigy software version 2.0, new functionalities have been integrated as the “Application Services” into the software. These services comprise a user management module including authentication features and an audit trail module which are essential to support 21 CFR Part 11 compatibility. When pressing the application services menu button, a pop-up window will appear which allows the selection of several service menus, e.g., Logout or User setup (see Figure 5.1).



Screen 5.1: Pop-up window “Application Services”

5.4.1 User Management

To establish the user management functionality on the CliniMACS Prodigy, it is necessary to create individual accounts for all users of a given instrument and to define their individual set of roles.

In principal, there are two main user categories: operators and administrators. An operator starts and runs applications on the CliniMACS Prodigy. Operator accounts must be set up to allow running a particular set of applications and some important tools for support and troubleshooting purposes. An administrator manages accounts and the instrument. The administrator account would typically allow the setup and changes of accounts and provides access to file management and advanced tools for instrument settings.

Creation of a new account

To create a new user account, **User setup** has to be selected within the pop-up window of the Application Services (see Figure 5.2) which leads to the **User Management** menu. For each account, user details, a password, and specific roles must be defined.

IMPORTANT

To enter the User Management menu, a user will need administration rights to do so. It is therefore essential to create administrator accounts upon installing software version 2.0 onto the instrument!

The **User Management** menu comprises four submenus (see Figure 5.2): **Users**, **LDAP Groups**, **Roles**, and **Configuration**. Upon selection of the **User Management** menu, the submenu **Users** is shown which contains a list of all previously set up accounts with all account details.

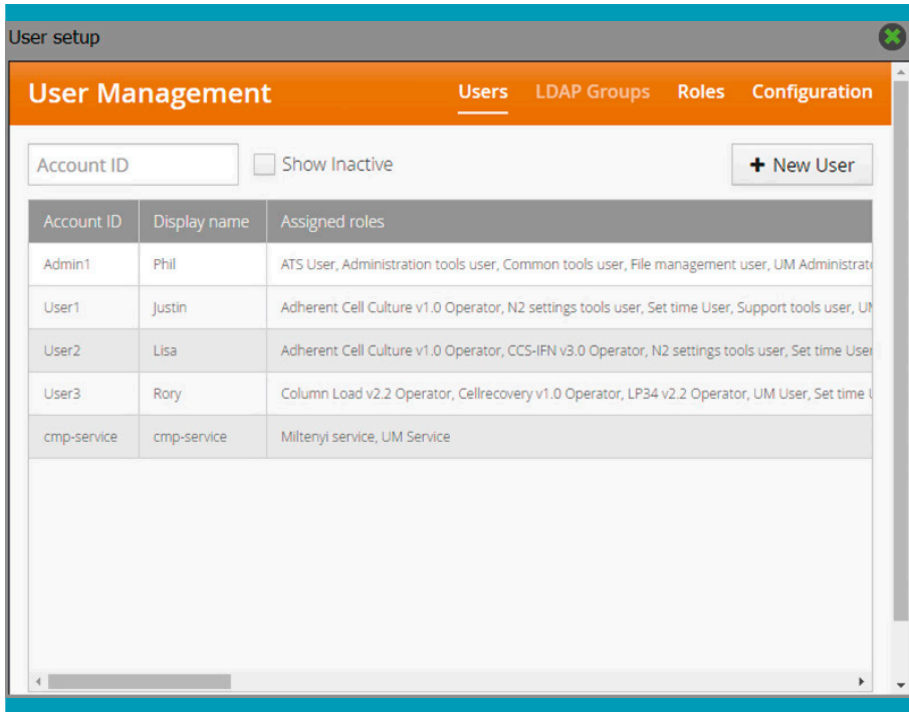

Screen 5.2: Menu "User Management"

Note: The submenu LDAP Groups is not active for use in software version 2.0. In addition, the displayed account "cmp-service" in the example shown in Figure 5.2 represents a pre-installed account for Miltenyi Biotec Instrument Service staff. Such accounts cannot be deleted nor adapted.

Pressing + **New User** leads to a new submenu for the creation of a new account with its own ID, user details, password, and the assignment of specific roles. All assignable roles are listed in the first tab **Role** under “Available Roles” (see Figure 5.3). This list includes operator roles for all applications (e.g., “CCS-IFN v3.0 Operator”) and tools (e.g., “Common tools user”) and administrator roles (e.g., “Administration tools user”). For further descriptions of the roles, see section “Roles and rights”.

After entering an account ID (e.g., “User4”), all required roles for this specific user can be selected by shifting these from the left window “Available Roles” to the right window “Assigned Roles” using the arrows between the two lists.

IMPORTANT

For an operator, the role “UM User” must be assigned. For an administrator, the role “UM Administrator” must be assigned.

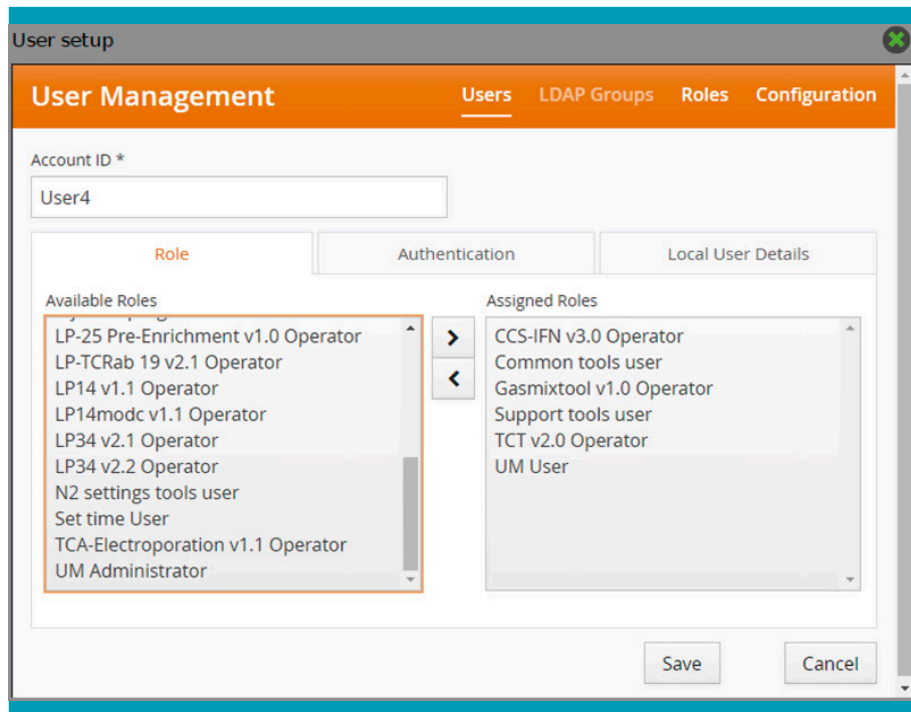

Screen 5.3: Assigning roles to a specific user

The password to this account has to be assigned by opening the tab **Authentication**. The password must be set according to the password policy which may be adapted in the submenu **Configuration** under tab **Password Policies**. Further user details, e.g., name, initials etc., can be defined by opening the third tab **Local User Details**. The new account is now saved and appears in the accounts list shown in Figure 5.2.

Note: For the descriptions in this user manual, “functional” user names like “User1” or “Admin1” have been chosen to better explain how to set up these accounts. In a true GMP environment, real names or synonyms which can be clearly differentiated and recognized must be used.

name	Description	Type
LP14modc internal v1.1 Operator	A trained operator for application LP14modc v1.1.	System
LP14modc v1.1 Operator	A trained operator for application LP14modc v1.1.	Standard
LP34 internal v2.1 Operator	A trained operator for application LP34 v2.1.	System
LP34 internal v2.2 Operator	A trained operator for application LP34 v2.2.	System
LP34 v2.1 Operator	A trained operator for application LP34 v2.1.	Standard
LP34 v2.2 Operator	A trained operator for application LP34 v2.2.	Standard
Miltenyi service	A service technician of Miltenyi Biotec.	System
N2 settings tools user	A user that can use N2 settings.	Standard
Set time User	A user that can change the time of the instrument.	Standard
Support tools user	A user that can use tools that support the execution of applications.	Standard

Screen 5.4: Submenu “Roles” with a list of existing roles

Roles and rights

The submenu **Roles** in the menu **User Management** contains a list with all available pre-defined roles for setting up user accounts and a short description of the individual roles (Figure 5.4). For further description, see Screen 5.1.

For administrators, it is possible to create new roles in a certain limited manner by using a list of rights for tools and applications in a new screen which is entered by pressing + **Add New Role**.

Note: This new window also contains rights for Miltenyi Biotec Instrument Service which are not activated for local administrators.

Screen 5.1 lists the different roles available in software version 2.0 and explains the tools or rights which are associated with this role. The specific applications which can be assigned to an operator are represented by "Application vx.x Operator".

Material	Quantity
Application vx.x operator	Permission to run this application with version number x.x
ATS user	Access to Audit Trail including the right to delete
Administration tools user	Access to tools for administrating the instrument
Common tools user	Access to common tools: info, license, shutdown, user settings
File management user	Allows backup of filed data and custom files
Gas mix tool v1.0 Operator	Access to the gas mix tool
Injected programs	Permission to run injected programs
N ₂ settings tools user	Access N ₂ settings tool
Set time user	Allows to set the time
Support tools user	Chamber in, chamber out, sealer, instrument check
UM Administrator	Access to the User Management allowing to manage accounts Note: The role must be assigned to an administrator.
UM user	Defined operator who shall start and run user applications Note: The role must be assigned to an operator.

Table 5.1: Description of different roles in software version 2.0

Configuration

The submenu **Configuration** in the menu **User Management** allows the setup of all relevant password settings, e.g., definition of characters to be used, password length, or number of login attempts according to the security guidelines of the customer under tab **Password Policy** (see Figure 5.5).

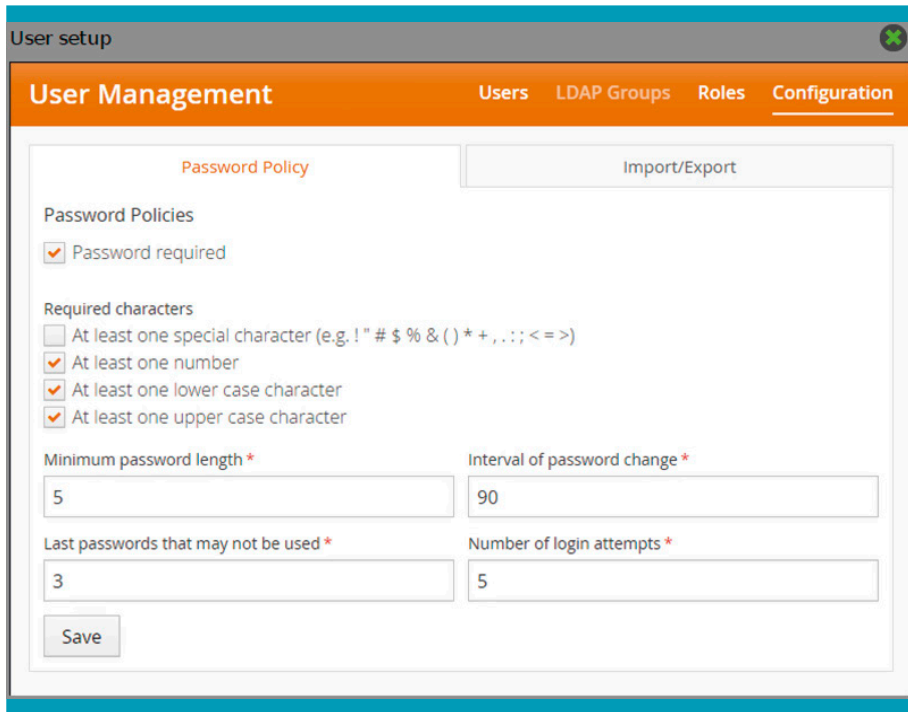

The screenshot shows a web application window titled "User setup" with a close button in the top right corner. The main content area is titled "User Management" and has four sub-tabs: "Users", "LDAP Groups", "Roles", and "Configuration" (which is currently active and underlined). Below the tabs, there are two sub-sections: "Password Policy" and "Import/Export". The "Password Policy" section contains the following settings:

- Password Policies:** A checkbox labeled "Password required" is checked.
- Required characters:** Four checkboxes are listed:
 - At least one special character (e.g. ! " # \$ % & () * + , . : ; < = >)
 - At least one number
 - At least one lower case character
 - At least one upper case character
- Minimum password length *:** A text input field containing the value "5".
- Interval of password change *:** A text input field containing the value "90".
- Last passwords that may not be used *:** A text input field containing the value "3".
- Number of login attempts *:** A text input field containing the value "5".

At the bottom left of the "Password Policy" section, there is a "Save" button.

Screen 5.5: Submenu "Configuration" with active "Password Policy" tab

Opening the tab **Import/Export** allows the export of user management setting like custom roles, user setups, or password policies onto a USB device which can be used for settings on different CliniMACS Prodigy in the same facility.

Audit Trail

Note: In order to enable a user to utilize audit trail functionality, the role “ATS User” must be assigned to this user. The default role “ATS User” allows users to read, export and delete audit trail events. It is possible for the administrator of a given user’s account to create a new role with reduced Audit Trail rights, e.g., to only read and export Audit Trail events (see also section “Roles and rights”).

The **Audit Trail** menu can be entered by selecting **Audit Reporting** in the pop-up window “Application Services” (see Figure 5.8). The menu contains a list of all available audit trail events on the instrument. This list can be filtered by date or the description of the events if needed. The screen in Figure 5.6 shows an example of eight events out of a list with 603 events in total. By scrolling through the list all events could be checked and eventually be exported, e.g., as a PDF to a USB device inserted to the CliniMACS Prodigy using the **Create Export** button.

The screenshot shows the 'Audit Reporting' window with a sub-header 'Audit Trail'. At the top right, it indicates '603 / 603' events. Below the header are two buttons: 'Create Export' and 'Delete Events'. A date range filter is set from '2020-Jul-17' to '2020-Aug-05', followed by a search box labeled 'Description'. The main area contains a table with the following data:

Time	Category	Type	User	Description
2020-Jul-21 10:33:44...	User Int..	pushbtn clic...	User1	user pauses the process
2020-Jul-21 10:33:42...	User Int..	popup close...	User1	Confirmation required' war
2020-Jul-21 10:33:38...	User Int..	popup close...	User1	Process paused' warningPr
2020-Jul-21 10:33:36...	User Int..	pushbtn clic...	User1	user pauses the process
2020-Jul-21 10:33:16...	User Int..	popup close...	User1	Integrity test - upper part' c
2020-Jul-21 10:33:11...	User Int..	pushbtn clic...	User1	user confirms 'Adherent Ce
2020-Jul-21 10:32:57...	User Int..	popup close...	User1	Intergrity test' operatorPro
2020-Jul-21 10:32:39...	User Int..	pushbtn clic...	User1	user confirms 'Adherent Ce

Screen 5.6: Menu “Audit Trail”

Similarly, a set of events within a selected time frame can be deleted by pressing the **Delete Events** button. In this case, a pop-up window appears, providing a statement that audit trail data should not be deleted before they had been archived (see Figure 5.7). The selected events will be deleted upon pressing **Continue Delete**. After the deletion of the events, a new audit trail event will be generated showing the time of deletion and the number of the deleted events.

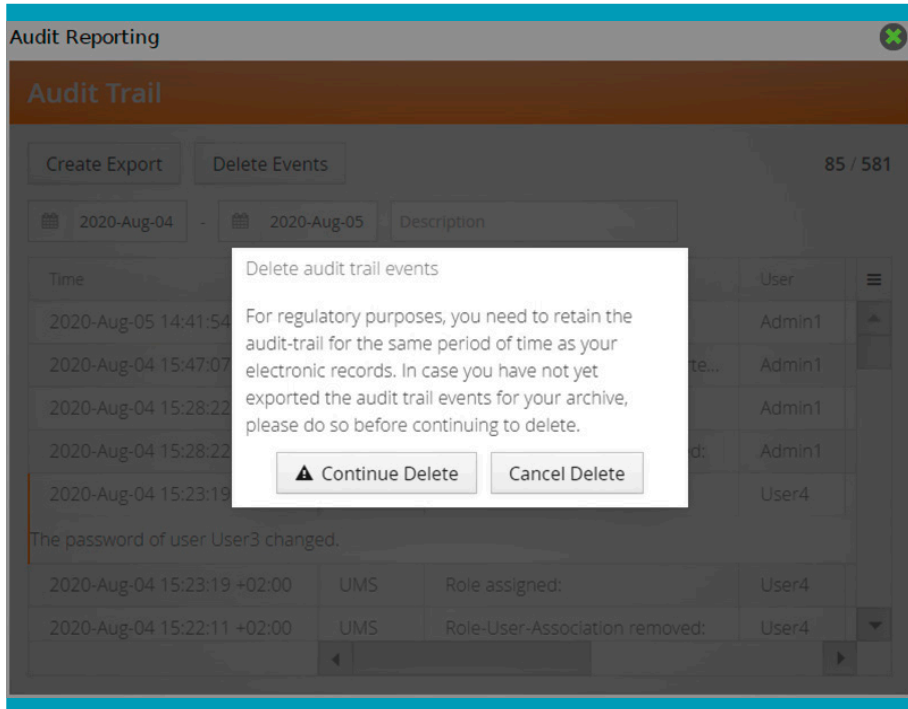

Screen 5.7: Menu "Audit Trail"

5.5 Alarm management

The CliniMACS Prodigy is equipped with an integrated alarm management system which is spread over several components, providing optical and acoustical alarm signals if required. An additional relay circuit may be connected to an external alarm system. Relay 1 indicates a critical situation which requires immediate user interaction. Relay 2 indicates a required user interaction (see also section 4.3.9 "Connector panel").

The alarm management system of the instrument features a three-level alarm system. In case of a failure, a message is displayed on the monitor, accompanied by an audible warning signal from a speaker within the touchscreen. The signal lamp at the bag hanger A (see Figure 4.3) will then display a red blinking light.

The instrument distinguishes between three alarm levels as described in Table 5.2.

Alarm level	Description
Level 1: Hint	A hint message is used to provide the user with information, e.g., on how to continue with the selected procedure. A user action may be necessary. If a user action is required, the signal lamp displays a blue blinking light. At this level, relay circuit 2 is inactive.
Level 2: Warning	A warning message shows warnings that require the user's attention, e.g., sensors detect unexpected values. If a warning message appears, the signal lamp displays a yellow blinking light. In addition, relay circuit 2 is active.
Level 3: Alarm	Alarm messages point out system interrupts referring to safety relevant steps that await an obligatory user action. If an alarm message appears, the signal lamp displays a red blinking light. In addition, the speaker provides an acoustical alarm signal and relay circuit 1 is active.

Table 5.2: Alarm levels of the instrument

The signal lamp

An LED signal lamp is positioned at the top end of the bag hanger A (see Figure 4.3). This signal lamp provides instrument status information by displaying different colors, as described in Table 5.3.

Color	Description
White	The instrument is ready for use and a process may be started.
Green	A process is running. No interaction required.
Blue	The instrument requires user interaction.
Yellow	Warning (time critical), user interaction required
Red	Alarm, critical situation, process failure possible, user interaction required

Table 5.3: Color code of the signal lamp

Note: Whenever a user interaction is required, the signal lights will blink. This is the case with the blue, yellow, and red color lights.

6

The CliniMACS Prodigy System

6.1 The CliniMACS Prodigy System components

The different applications run on the CliniMACS Prodigy require the use of specific CliniMACS Prodigy System components as well as additional materials and equipment as described in the CliniMACS Prodigy user manual (U.S. Edition) for the respective application. The following CliniMACS Materials may be part of a CliniMACS Prodigy System:

- **The CliniMACS Prodigy** including the accessories MACS TubeSealer, bar code reader, and CliniMACS Prodigy Supplementary Bag (as described in this user manual).
- **CliniMACS Reagents and Biotin Conjugates** are intended for *in vitro* use only and are not designated for therapeutic use or direct infusion into patients. CliniMACS Reagents and Biotin Conjugates in combination with the CliniMACS System are intended to separate human cells. The CliniMACS Reagents are dark colored, non-viscous, colloidal solutions containing the cell specific antibody conjugates in buffer. The reagents consist of the antibody chemically coupled to super-paramagnetic particles. The CliniMACS Biotin Conjugates are clear and colorless solutions containing antibody covalently linked to biotin in buffer. The antibodies are highly specific, making labeling of rare target cells possible.
- **CliniMACS Prodigy Tubing Sets** are intended for *in vitro* separation or other processing of human cells from heterogeneous haematologic cell populations in combination with the CliniMACS Prodigy System only. The different tubing sets have been developed for the special requirements of the respective application for use in combination with the CliniMACS Prodigy System only. They consist of pre-assembled tubing, pre-assembled bags, and other components as required.

- **CliniMACS PBS/EDTA Buffer (3000 mL)** is intended for the *in vitro* separation of human cells in combination with the CliniMACS Prodigy System only. It is used as process buffer during cell separation and is provided in 3000 mL sterilized plastic bags, individually packed.

IMPORTANT

For instructions for use, e.g., warnings and precautions concerning the CliniMACS Prodigy System components, refer to the instructions for use provided for the respective component.

6.2 Additional materials and equipment

Additional materials, e.g., CliniMACS Prodigy Accessories or MACS GMP Products, and equipment required for the different applications are described in the CliniMACS Prodigy user manual (U.S. Edition) of the respective application.

IMPORTANT

The procedures may require the use of components which are not part of the CliniMACS Prodigy System. Therefore, either materials of pharmaceutical grade must be used or the user has to evaluate all risks arising from these materials. In addition, no inflammable or explosive materials should be used, or solutions that will lead to a hazardous chemical reaction that could represent a potential risk for the user.

6.3 Limitation

Miltenyi Biotec as the manufacturer of the CliniMACS System does not give any recommendations regarding the use of separated cells for therapeutic purposes and does not make any claims regarding a clinical benefit.

6.4 Warnings and precautions regarding the process

WARNING

Risk of process failure or damage to the instrument. Risk of process failure or damage to the instrument if procedures are performed by untrained operators. All processing procedures must be performed by trained operators only. Operator training will be provided by a qualified Miltenyi Biotec representative.

- Before human applications, the suitability of the target cells must be demonstrated regarding indication, quality, and quantity.
- Further processing and use for clinical applications must be in accordance with FDA investigational use regulations.
- Any clinical application of the separated or otherwise processed cells is exclusively within the responsibility of the user.
- All materials, which have come into contact with blood and blood products, must be treated as infectious material. Regulations for the handling of infectious material must be observed.
- All cell preparation and labeling procedures must be performed at room temperature (+19 to +25 °C [+66 to +77 °F]) unless otherwise stated. Higher or lower temperatures may result in reduced purity and lower yield of the target cells.
- All tubing, fittings, valves, the pre-column, and the separation column should be checked thoroughly for leaks during the priming step.
- All bags should be retained until final analysis of all cells has been completed and successful processing of the target cells has been confirmed.

6.5 Warnings and precautions regarding the handling of biohazardous material

- To avoid contamination of the cellular starting product, all preparation steps should be performed using aseptic techniques.
- The operator performing the cell processing must be trained in the proper use of the equipment and in the handling of blood products and bone marrow aspirates.
- The operator performing the cell separation should wear appropriate clothing (e.g., lab coat, gloves, and protective glasses or goggles) when working with a patient sample and handling potentially biohazardous material.
- All blood products must be treated as a potential biohazard. Leukapheresis product, blood product, bone marrow aspirate, collected cells, used buffer, used tubing set, and other materials, which have been in contact with these fluids, must be treated as biohazardous materials according to standard hospital or institutional requirements.
- The CliniMACS Prodigy should be considered as potential biohazard after each run and cleaned with an aqueous biocidal detergent (see section 4.6 “Cleaning and disinfection”) according to standard hospital or institutional requirements.
- Disposable materials must be treated according to standard hospital or institutional requirements for biohazardous materials.

6.6 Warnings and precautions regarding the cellular starting product

IMPORTANT

Labeling and processing of cells should begin as soon as possible after the cellular starting product has been collected. It is recommended to start all labeling and processing procedures within 24 h after the cell collection.

- The cellular starting product (e.g., leukapheresis product, buffy coat, etc.) should be collected according to standard hospital or institutional procedures in standard collection bags. Bone marrow aspirate should be collected in heparin-coated containers (e.g., 5 mL syringes). Prior to the cell labeling procedure, no additional anticoagulants or blood additives (heparin, etc.) should be included beyond those normally used during leukapheresis or during bone marrow aspiration.
- The container with the cellular starting product should be labeled with patient identification, time, date, and place of collection according to procedures specified for use with the clinical protocol.
- For transportation, the cellular starting product should be packed in insulated containers and be kept at controlled room temperature (+19 to +25 °C [+66 to +77 °F]) according to standard hospital or institutional blood collection procedures approved for use with the clinical protocol. Do not refrigerate. The cell concentration should not exceed 0.2×10^9 cells per mL during transportation.
- For transportation of the bone marrow aspirate, the product should be packed in insulated containers and be kept at controlled temperature (+2 to +8 °C [+36 to +46 °F]).
- Avoid intensive mixing of the cellular starting material.
- If the cellular starting product has to be stored, e.g., overnight, it should be kept at controlled room temperature (+19 to +25 °C [+66 to +77 °F]). Bone marrow aspirate should be kept at controlled temperature (+4 °C [+39 °F]). During storage, the concentration of leukocytes should never exceed 0.2×10^9 cells per mL.
- Cells should be stored in autologous plasma. If the cell concentration is higher than 0.2×10^9 cells per mL, dilute the cellular starting product with autologous plasma.

7

Troubleshooting

7.1 Instrument malfunction or process failure

In any case of instrument malfunction or process failure, contact the Miltenyi Biotec Technical Support:

☎ +49 2204 8306-3803

✉ technicalsupport@miltenyi.com

Visit www.miltenyibiotec.com for local Miltenyi Biotec Technical Support contact information.

7.2 Instrument cleaning after leakage

In case leakage occurs, e.g., in the CentriCult Unit, additional cleaning measures are required. For further information contact the Miltenyi Biotec Technical Support.

8

Legal notes

8.1 Limited warranty

Except as stated in a specific warranty statement, which may accompany this Miltenyi Biotec product, or unless otherwise agreed in writing by a duly authorized Miltenyi Biotec representative, Miltenyi Biotec's warranty for products purchased directly from Miltenyi Biotec shall be subject to the terms and conditions of sale under which it was provided to you by the respective Miltenyi Biotec sales organization. These terms and conditions are available on request or at www.miltenyibiotec.com. The applicable terms and conditions of sale may vary by country and region. Nothing herein should be construed as constituting an additional warranty.

For products purchased from third-party retailers or resellers (e.g., purchased from an authorized local Miltenyi Biotec Service Provider), different terms and conditions may apply.

To determine the warranty that came with your product, see your packing slip, invoice, receipt or other sales documentation. Some components of a product combination you purchased may have a shorter warranty than that listed on your packing slip, invoice, receipt or other sales documentation (e.g., goods subject to shelf life and obsolescence).

Miltenyi Biotec's warranty for this product only covers product issues caused by defects in material or workmanship during normal use. It does not cover product issues caused by any other reason, including but not limited to product issues due to use of the product in a manner other than specifically described in this manual, for example: inappropriate or improper use; incorrect assembly or installation by an operator or a third party; reasonable wear and tear; negligent or incorrect operation, handling, storage, servicing, or maintenance;

non-adherence to the operating instructions; unauthorized modification of or to any part of this product; or use of inappropriate consumables, accessories, or work materials.

Miltenyi Biotec's warranty does not cover products sold AS IS or WITH ALL FAULTS or consumables. Nothing herein should be construed as constituting an additional warranty.

Miltenyi Biotec must be informed immediately if a claim is made under such warranty. If a material or manufacturing defect occurs within the warranty period, Miltenyi Biotec will take the appropriate steps to restore the full usability of the instrument.

Limitation on damages

Miltenyi Biotec shall not be liable for any incidental or consequential damages for breach of any express or implied warranty or condition on this product.

Some countries/states or jurisdictions do not allow the exclusion or limitation of incidental or consequential damages, so the above limitations or exclusions may not apply to you. This warranty statement gives you specific legal rights and you may have other rights which vary from state to state or jurisdiction to jurisdiction.

8.2 Trademarks

CentriCult, CliniMACS, CliniMACS Prodigy, MACS, the Miltenyi Biotec logo, PepTivator, and TexMACS are registered trademarks or trademarks of Miltenyi Biotec B.V. & Co. KG and/or its affiliates in various countries worldwide. All other trademarks mentioned in this document are the property of their respective owners and are used for identification purposes only.

APPENDIX

Guidance and manufacturer's declaration on electromagnetic compatibility

EMC compliance with IEC 60601-1-2:2014+AMD1:2020 (Edition 4.1) has been attested for the CliniMACS Prodigy and the approved accessories (see Table 4.3). The use of other power cables may result in increased electromagnetic emissions or decreased immunity of the CliniMACS Prodigy. If the provided power cable is missing, contact Miltenyi Biotec Technical Support.

Guidance and manufacturer's declaration – Electromagnetic emissions

The CliniMACS Prodigy is intended for use in the electromagnetic environment specified below. The customer or the user of the instrument should assure that it is used in such an environment.

Emissions test	Compliance
RF Emissions CISPR 11/32	Group 1
Bursts IEC 61000-4-4	Class A
Harmonic emissions IEC 61000-3-2	Class A
Voltage fluctuations/Flicker emissions IEC 61000-3-3	Complies

Table A.1: Guidance and manufacturer's declaration – Electromagnetic emissions

 **WARNING**

Use of this instrument adjacent to or stacked with other equipment should be avoided because it could result in improper operation. If such use is necessary, this equipment and the other equipment should be observed to verify that they are operating normally.

Based on technical limitations of the internal power supply voltage, interruptions on power supply input lines for longer than 10 ms may lead to cessation of the separation process (power failure). The separation process cannot be resumed after a power failure. It is recommended that the instrument is powered from an uninterruptible power supply or a battery that starts within 10 ms.

Guidance and manufacturer's declaration – Electromagnetic immunity

The MACS TubeSealer is intended for use in the electromagnetic environment specified below. The customer or the user of the heat sealer should assure that it is used in such an environment.

Immunity tests	EN IEC 60601 Test level	Compliance level
Electrostatic discharge (ESD) IEC 61000-4-2	±8 kV contact discharge ±2 kV, ±4 kV, ±8 kV, ±15 kV air discharge	±8 kV contact discharge ±2 kV, ±4 kV, ±8 kV, ±15 kV air discharge
Electrical fast transients (Bursts) IEC 61000-4-4	±2 kV 100 kHz repetition frequency Power supply lines ±1 kV 100 kHz repetition frequency Input/output lines	±2 kV 100 kHz repetition frequency Power supply lines ±1 kV 100 kHz repetition frequency Input/output lines
Surges IEC 61000-4-5	±0.5 kV, ±1 kV line to line ±0.5 kV, ±1 kV, ±2 kV line to ground	±0.5 kV, ±1 kV line to line ±0.5 kV, ±1 kV, ±2 kV line to ground
Voltage dips, interruptions, and variations IEC 61000-4-11	0% U_T during 0.5 cycle at 0°, 45°, 90°, 135°, 180°, 225°, 270°, 315° 0% U_T during 1 cycle and 70% U_T during 25/30 cycles (single phase) at 0° 0% U_T during 250/300 cycle	0% U_T during 0.5 cycle at 0°, 45°, 90°, 135°, 180°, 225°, 270°, 315° 0% U_T during 1 cycle and 70% U_T during 25/30 cycles (single phase) at 0°
Rated power frequency magnetic field IEC 61000-4-8	30 A/m 50 Hz or 60 Hz	30 A/m 50 Hz or 60 Hz
Conducted disturbances induced by RF fields IEC 61000-4-6	3 V (0.15 MHz to 80 MHz) 6 V in ISM bands between 0.15 MHz and 80 MHz 80% AM at 1 kHz	3 V (0.15 MHz to 80 MHz) 6 V in ISM bands between 0.15 MHz and 80 MHz 80% AM at 1 kHz
Radiated RF EM fields IEC 61000-4-3	3 V/m (80 MHz–2.7 GHz) 80% AM at 1 kHz	3 V/m (80 MHz–2.7 GHz) 80% AM at 1 kHz
Proximity fields from RF wireless communication equipment IEC 61000-4-3	See Table A.3: Specifications for immunity to RF wireless communication equipment	See Table A.3: Specifications for immunity to RF wireless communication equipment
Proximity magnetic fields in the frequency range from 9 kHz to 13.56 MHz IEC 61000-4-39	See Table A.4: Specification for immunity to proximity magnetic fields in the frequency range from 9 kHz to 13.56 MHz	See Table A.4: Specification for immunity to proximity magnetic fields in the frequency range from 9 kHz to 13.56 MHz

Table A.2: Guidance and manufacturer's declaration – Electromagnetic immunity

Guidance and manufacturer's declaration – Electromagnetic immunity to RF wireless communication equipment

Test frequency (MHz)	Band (MHz)	Service	Modulation	Immunity test level (V/m)	Compliance level (V/m)
385	380 – 390	TETRA 400	Pulse Modulation 18 Hz	27	27
450	430 – 470	GMRS460, FRS460	FM ±5 kHz deviation 1 kHz sine	28	28
710 745 780	704 – 787	LTE Band 13, 17	Pulse modulation 217 Hz	9	9
810 870 930	800 – 960	GSM 800/900, TETRA 800, iDEN 820, CDMA 850, LTE Band 5	Pulse modulation 217 Hz	28	28
1720 1845 1970	1700 – 1990	GSM 1800; CDMA 1900; GSM 1900; DECT; LTE Band 1, 3, 4, 25; UMTS	Pulse modulation b) 217 Hz	28	28
2450	2400 – 2570	Bluetooth, WLAN, 802.11 b/g/n, RFID 2450, LTE Band 7	Pulse modulation 217 Hz	28	28
5240 5500 5785	5100 – 5800	WLAN 802.11 a/n	Pulse modulation 217 Hz	9	9

Table A.3: Guidance and manufacturer's declaration – Electromagnetic immunity to RF wireless communication equipment

Guidance and manufacturer's declaration – Electromagnetic immunity to proximity magnetic fields in the frequency range 9 kHz to 13.56 MHz

Test frequency	Modulation	Immunity Test Level (A/m)	Compliance Level (A/m)
134.2 kHz	Pulse modulation 2.1 kHz	65	65
13.56 MHz	Pulse modulation 50 kHz	7.5	7.5

Table A.4: Guidance and manufacturer's declaration – Electromagnetic immunity to proximity magnetic fields in the frequency range 9 kHz to 13.56 MHz

WARNING

Degradation of the performance of the heat sealer. Degradation of the performance of this equipment if portable RF communications equipment is used in close proximity to any part of the heat sealer. Portable RF communications equipment (including peripherals such as antenna cables and external antennas) should be used no closer than 30 cm (12 inches) to any part of the heat sealer, including cables specified by the manufacturer.



Miltenyi Biotec

Germany/Austria

Miltenyi Biotec B.V. & Co. KG
Friedrich-Ebert-Straße 68
51429 Bergisch Gladbach
Germany
☎ +49 2204 8306-0
✉ +49 2204 85197
✉ macsde@miltenyi.com

USA/Canada

Miltenyi Biotec Inc.
2303 Lindbergh Street
Auburn, CA 95602
USA
☎ 800 FOR MACS
☎ +1 866 811 4466
✉ +1 877 591 1060
✉ macsus@miltenyi.com

Australia

Miltenyi Biotec
Australia Pty. Ltd.
Unit 11, 2 Eden Park Drive
Macquarie Park NSW 2113
Australia
☎ +61 2 8877 7400
✉ +61 2 9889 5044
✉ macsau@miltenyi.com

Benelux

Miltenyi Biotec B.V.
Dellaertweg 9C
2316 WZ Leiden
The Netherlands
✉ macsnl@miltenyi.com
Customer service The Netherlands
☎ 0800 4020120
✉ 0800 4020100
Customer service Belgium
☎ 0800 94016
✉ 0800 99626
Customer service Luxembourg
☎ 800 24971
✉ 800 24984

China

Miltenyi Biotec Technology &
Trading (Shanghai) Co., Ltd.
Room A401, 4/F
No. 1077, Zhangheng Road
Pudong New Area
201203 Shanghai
P.R. China
☎ +86 21 6235 1005-0
✉ +86 21 6235 0953
✉ macscn@miltenyi.com.cn

France

Miltenyi Biotec SAS
10 rue Mercoeur
75011 Paris
France
☎ +33 1 56 98 16 16
✉ macsfr@miltenyi.com

Hong Kong

Miltenyi Biotec Hong Kong Ltd.
Unit 301, Lakeside 1
No. 8 Science Park West Avenue
Hong Kong Science Park
Pak Shek Kok, New Territories
Hong Kong
☎ +852 3751 6698
✉ +852 3619 5772
✉ macshk@miltenyi.com.hk

Italy

Miltenyi Biotec S.r.l.
Via Paolo Nanni Costa, 30
40133 Bologna
Italy
☎ +39 051 6 460 411
✉ +39 051 6 460 499
✉ macsit@miltenyi.com

Japan

Miltenyi Biotec K.K.
NEX-Eitai Building 5F
16-10 Fuyuki, Koto-ku
Tokyo 135-0041
Japan
☎ +81 3 5646 8910
✉ +81 3 5646 8911
✉ macsjp@miltenyi.com

Nordics and Baltics

Miltenyi Biotec Norden AB
Medicon Village
Scheeleorget 1
223 81 Lund
Sweden
✉ macsse@miltenyi.com
Customer service Sweden
☎ 0200 111 800
✉ +46 280 72 99

Customer service Denmark

☎ 80 20 30 10
✉ +46 46 280 72 99

Customer service

**Norway, Finland, Iceland,
and Baltic countries**
☎ +46 46 280 72 80
✉ +46 46 280 72 99

Singapore

Miltenyi Biotec Asia Pacific Pte Ltd.
438B Alexandra Road, Block B
Alexandra Technopark
#06-01
Singapore 119968
☎ +65 6238 8183
✉ +65 6238 0302
✉ macssg@miltenyi.com

South Korea

Miltenyi Biotec Korea Co., Ltd.
Donggeuk 7F
562 Nonhyeon-ro
Gangnam-gu
Seoul 06136
South Korea
☎ +82 2 555 1988
✉ +82 2 555 8890
✉ macskr@miltenyi.com

Spain

Miltenyi Biotec S.L.
C/Luis Buñuel 2
Ciudad de la Imagen
28223 Pozuelo de Alarcón (Madrid)
Spain
☎ +34 91 512 12 90
✉ +34 91 512 12 91
✉ macses@miltenyi.com

Switzerland

Miltenyi Biotec Swiss AG
Gibelinstrasse 27
4500 Solothurn
Switzerland
☎ +41 32 623 08 47
✉ +49 2204 85197
✉ macsch@miltenyi.com

United Kingdom

Miltenyi Biotec Ltd.
Almac House, Church Lane
Bisley, Surrey GU24 9DR
United Kingdom
☎ +44 1483 799 800
✉ +44 1483 799 811
✉ macsuk@miltenyi.com

🏠 www.miltenyibiotec.com

Miltenyi Biotec provides products and services worldwide. Visit www.miltenyibiotec.com/local to find your nearest Miltenyi Biotec contact.

CentriCult, CliniMACS, CliniMACS Prodigy, MACS, the Miltenyi Biotec logo, PepTivator, and TexMACS are registered trademarks of Miltenyi Biotec B.V. & Co. KG and/or its affiliates in various countries worldwide. Copyright © 2023 Miltenyi Biotec and/or its affiliates. All rights reserved.